

CLINICAL UPDATE

Australian and New Zealand

# Chronic Hepatitis B (CHB) Recommendations

2ND EDITION 2009/10

© DIGESTIVE HEALTH FOUNDATION 2009/10

# TABLE OF CONTENTS

CHAPTER		PAGE
1.	<b>CHRONIC HEPATITIS B VIRUS DISEASE BURDEN IN AUSTRALIA AND NEW ZEALAND</b>	<b>7</b>
	AUSTRALIA	7
	NEW ZEALAND	7
2.	<b>SCREENING IN HIGH-RISK GROUPS</b>	<b>8</b>
3.	<b>NATURAL HISTORY</b>	<b>9</b>
	ACUTE HBV	9
	PROGRESSION TO CHRONIC HBV INFECTION	9-10
	DISEASE PROGRESSION	10-11
4.	<b>RECOMMENDATIONS FOR PATIENT EVALUATION</b>	<b>12</b>
	DIAGNOSIS	12
	BASELINE EVALUATION	12
5.	<b>CHB TREATMENT GOALS AND OBJECTIVES</b>	<b>12</b>
	TREATMENT GOAL	12
	TREATMENT OBJECTIVES	12-13
	PATIENTS TO TREAT	13
	TREATMENT OPTIONS	14-16
6.	<b>MONITORING ON AND OFF-TREATMENT RESPONSE</b>	<b>16</b>
	NOT CURRENTLY RECEIVING TREATMENT	16
	TREATMENT WITH NUCLEOSIDE / NUCLEOTIDE ANALOGUES	17-18
	TREATMENT WITH PegIFN	19
7.	<b>TREATMENT OF HBeAg-POSITIVE CHB</b>	<b>20</b>
	FIRST LINE TREATMENT OPTIONS	20-21
	ANTIVIRAL AGENTS IN HBeAg-POSITIVE CHB	22-23

<b>CHAPTER</b>		<b>PAGE</b>
<b>8.</b>	<b>TREATMENT HBeAg-NEGATIVE CHB</b>	<b>24</b>
	FIRST LINE TREATMENT OPTIONS	24
	ANTIVIRAL AGENTS IN HBeAg-NEGATIVE CHB	25
<b>9.</b>	<b>MANAGING ANTIVIRAL RESISTANCE</b>	<b>26</b>
	CLINICAL CONSEQUENCES OF RESISTANCE	26
	DYNAMICS AND DEFINITIONS OF RESISTANCE	26-27
	PATHWAYS AND PATTERNS OF RESISTANCE MUTATIONS	27-28
	CROSS RESISTANCE	28-29
	RATES OF RESISTANCE	29-30
	RESISTANCE PREVENTION STRATEGIES	30
	MONITORING VIROLOGIC RESPONSE AND BREAKTHROUGH	30
<b>10.</b>	<b>COMBINATION AND DUAL THERAPY STRATEGIES</b>	<b>31</b>
	COMBINATION THERAPY	31-33
	DUAL THERAPY	33
<b>11.</b>	<b>TREATMENT OF PATIENTS WITH CIRRHOSIS</b>	<b>34</b>
	GOALS OF THERAPY	34
	RISK FACTORS	34
	PATIENTS TO TREAT	34
	TREATMENT CONSIDERATIONS	34-35
<b>12.</b>	<b>SPECIAL POPULATIONS</b>	<b>36</b>
	HIV/HBV CO-INFECTION	36-37
	HBV/HCV CO-INFECTION	37-38
	HBV/HDV CO-INFECTION	38
	CHEMO- AND IMMUNOSUPPRESSIVE THERAPY	38-39
	LIVER TRANSPLANT PATIENTS	39-40
	PREGNANCY/LACTATION	40-41
<b>13.</b>	<b>REFERENCES</b>	<b>42</b>

## **DIGESTIVE HEALTH FOUNDATION**

Established in 1990, the Digestive Health Foundation (DHF) is an educational body committed to promoting better health for all Australians by developing education and community health programs to improve awareness and understanding of digestive diseases.

Research and education into gastrointestinal disease are essential to contain the effects of these disorders on all Australians.

The DHF is the educational arm of the Gastroenterological Society of Australia, the professional body representing the specialty of gastrointestinal and liver disease in Australia. Members of the Society include physicians, surgeons, scientists and other medical specialties with an interest in GI disorders.

Guidelines for General Practitioners and patient leaflets are available on a range of topics related to GI disorders. Copies are available by contacting the Secretariat at the address below.

## **DIGESTIVE HEALTH FOUNDATION**

Gastroenterological Society of Australia

PO Box 508, Mulgrave

Victoria 3170, Australia

Phone: 1300 766 176

E-mail: [gesa@gesa.org.au](mailto:gesa@gesa.org.au)

Website: [www.gesa.org.au](http://www.gesa.org.au)

## AUSTRALIA AND NEW ZEALAND CHB REVIEW PANEL

### Chair:

Associate Professor William Sievert, Monash Medical Centre, Victoria

### Final Review Committee:

Associate Professor Greg Dore, National Centre in HIV Epidemiology and Clinical Research, NSW

Professor Stephen Locarnini, Victorian Infectious Disease Reference Laboratory, Victoria

Professor Peter Angus, Austin Health, Victoria

Associate Professor Paul Desmond, St Vincents Hospital, Victoria

Dr Frank Weilert, Waikato Hospital, Hamilton New Zealand

Associate Professor Simone Strasser, Royal Prince Alfred Hospital, NSW

### Contributors:

Professor Peter Angus, Austin Health, Victoria

Professor Bob Batey, Bankstown Hospital, NSW

Dr Wendy Cheng, Royal Perth Hospital, WA

RN Sarah Chivers, Box Hill Hospital, Victoria

Professor Graham Cooksley, RBH Research Foundation, QLD

Dr Josh Davis, Menzies School of Health Research and Charles Darwin University, NT

Associate Professor Paul Desmond, St Vincents Hospital, Victoria

Dr Anouk Dev, Monash Medical Centre, Victoria

Associate Professor Greg Dore, National Centre in HIV Epidemiology and Clinical Research, NSW

Professor Jacob George, Westmead Hospital, NSW

Dr Hugh Harley, Royal Adelaide Hospital, SA

Dr Alice Lee, Concord Hospital, NSW

Professor Barbara Leggett, Royal Brisbane & Women's Hospital, QLD

Dr Marc Le Mire, Royal Adelaide Hospital, SA

Dr Miriam Levy, Liverpool Hospital, NSW

Professor Stephen Locarnini, Victorian Infectious Disease Reference Laboratory, Victoria

Dr Jenny McDonald, Illawarra Health, NSW

Associate Professor Graeme Macdonald, Princess Alexandra Hospital, QLD

Dr Gerry MacQuillan, Sir Charles Gairdner Hospital, WA

Dr Stephen Pianko, Alfred Hospital, Victoria

Dr John Ring, Flinders Medical Centre, SA

Associate Professor Stuart Roberts, Alfred Hospital, Victoria

Dr Ferry Rusli, Monash Medical Centre, Victoria

Associate Professor William Sievert, Monash Medical Centre, Victoria

Dr Nigel Stace, Wellington Hospital, Wellington NZ

Associate Professor Simone Strasser, Royal Prince Alfred Hospital, NSW

Dr Alex Thompson, St. Vincent's Hospital, Victoria

Dr Philip Wong, Mercy Specialist Centre, Auckland NZ

Dr Frank Weilert, Waikato Hospital, Hamilton New Zealand

Dr Elke Wiseman, Liverpool Hospital, NSW

RN Rachel Wundke, Flinders Medical Centre, SA

### Acknowledgements:

These guidelines were supported and sponsored by the Gastroenterological Society of Australia and an unrestricted educational grant from Gilead Sciences (Australia and NZ).

### Recommendations Application Statement:

These recommendations have been prepared by Ceutica Medical Communications Pty Ltd. for the Gastroenterological Society of Australia and every care has been taken in their compilation. The recommendations are intended to be used as a guide only. The Ceutical Medical Communications Pty Ltd., Gastroenterological Society of Australia and the compilers of these recommendations shall not be liable to users of these guidelines nor to any other person, firm, company or other body for any loss, direct, indirect or consequential, on whatsoever account for any omission or negligent mis-statement contained herein, or by reason of, arising from or in relation to any such user, by any other person, company or body relying or acting upon or purporting to rely or act upon any matter contained therein or arising thereout.

## GLOSSARY OF ACRONYMS

ADV	adefovir dipivoxil	HDV	hepatitis D virus
AIDS	acquired immunodeficiency syndrome	HIV	human immunodeficiency virus
ALT	alanine aminotransferase	HRQoL	health-related quality of life
anti-HAV IgM	IgM antibody to hepatitis A	IDU	injecting drug user
anti-HBc	antibodies to the HBc (core) antigen	IFN	standard interferon alfa (2a or 2b)
anti-HBe	antibodies to the HBe antigen	INR	international normalised ration
anti-HBs	antibodies to the HBs (surface) antigen	ITT	intention-to-treat
ART	antiretroviral treatment	IU	International Units
CHB	chronic hepatitis B	LAM	lamivudine
CHC	chronic hepatitis C	LAM-R	lamivudine resistance
CI	confidence interval	MIU	million international units
DNA	deoxyribonucleic acid	ml	millilitre
ETV	entecavir	MU	million units
FTC	emtricitabine	PCR	polymerase chain reaction
HAART	highly active antiretroviral therapy	pegIFN	pegylated interferon alfa (2a or 2b)
HAI	histological activity index	QALY	quality-adjusted life-year
HAV	hepatitis A virus	QoL	quality of life
HBcAg	hepatitis B core antigen	RCT	randomised controlled trial
HBeAg	hepatitis B e antigen	RNA	ribonucleic acid
HBIG	hepatitis B immunoglobulin	TDF	tenofovir
HBsAg	hepatitis B s (surface) antigen	ULN	upper limit of normal range
HBV	hepatitis B virus		
HCC	hepatocellular carcinoma		
HCV	hepatitis C virus		

## QUALITY OF EVIDENCE ON WHICH A RECOMMENDATION IS BASED

Grade	Definition
I	Randomised controlled trials.
II-1	Controlled trials without randomisation.
II-2	Cohort or case controlled studies.
II-3	Multiple time series, dramatic uncontrolled experiments.
III	Opinion of respected authorities. Descriptive epidemiology.

## 1 CHRONIC HEPATITIS B VIRUS DISEASE BURDEN IN AUSTRALIA AND NEW ZEALAND

While prophylactic vaccination has significantly reduced the incidence of de novo hepatitis B virus (HBV) infections among populations where it has been introduced,<sup>1</sup> chronic hepatitis B (CHB) infection remains a serious global public health challenge.<sup>1</sup>

CHB affects over 400 million people worldwide, approximately 75% of whom reside in Asia and the Western Pacific.<sup>2</sup> Although many individuals eventually achieve a state of nonreplicative infection, the prolonged immunological response to infection leads to the development of cirrhosis, liver failure, or hepatocellular carcinoma (HCC) in up to 40% of people.<sup>3</sup> Each year around 1.2 million die of HBV-related chronic liver disease.<sup>4-6</sup> CHB is the major cause of HCC, causing 60-80% of the world's liver cancer.

Acute and chronic HBV infection is a major public health problem in Australia and New Zealand even though both countries are considered by the World Health Organisation (WHO) to have a low prevalence (<2%) of HBV infection. However population groups with a high prevalence of HBV markers exist within both countries.

### Australia

Recent estimates of the prevalence of CHB infection obtained from the first national serosurvey in Australia in 1996-99 range from 91,500 to 163,500 persons (0.49-0.87%).<sup>7,8</sup>

This is considerably more than the number infected with the human immunodeficiency virus (HIV) and comparable to the estimated 260,000 people infected with hepatitis C virus (HCV) infection. There are 6,000-8,000 new notifications to the National Notifiable Diseases Surveillance System (NNDSS) annually.<sup>9</sup> A large proportion of these infections are known to occur in selected populations, including indigenous people. Studies in the 1980s and early 1990s estimated that nearly half of all indigenous schoolchildren had serological markers of HBV infection<sup>10,11</sup> and up to 26% of rural Aboriginal and Torres Strait Islander populations were HBsAg positive.<sup>11-13</sup> In 1991-1995, the death rates (for all causes of chronic liver disease and cirrhosis) were 4 and 5.5 times higher for Aboriginal men and women, respectively, compared with rates for the general Australian population.

A more recent report showed that HBV notification and hospitalisation rates in Australia are at least four times higher in Aboriginal and Torres Strait Islander people.<sup>14</sup> The seroprevalence of HBV infection is likely to differ significantly from the national rate in some areas, particularly the Northern Territory, where approximately 25% of the population is indigenous and universal infant HBV immunisation has been in place since 1990.<sup>15</sup>

Immigrants from South-East Asia and the Pacific Islands (HBV prevalence 5-15%) or Southern Europe and the Mediterranean (2-5%) also have a significantly higher prevalence of CHB. In a recent study of over 2,000 patients undergoing gastrointestinal endoscopy in a Sydney teaching hospital, birth in Asia or the Pacific Islands was associated with a 12-fold increase in risk for hepatitis B infection while birth in the Middle East or Mediterranean countries was associated with a 6-fold increased risk.<sup>16</sup> Thus specific population risk factors may influence resource allocation for antiviral therapy and treatment of HBV complications such as cirrhosis, portal hypertension and hepatocellular carcinoma.

Evidence of the expanding burden of CHB related liver disease in Australia can be found in the NSW Cancer Registry and National Death Index. Between 1990 and 2002, deaths from CHB doubled from 100 to near 200 per annum. People with CHB had a 40-90% increased risk of mortality compared to a matched population and the risks of total liver disease-related and liver cancer-related mortality were 12 and 28 times higher respectively, than those for the background population.<sup>17</sup> The burden of CHB including HBV-related HCC among Asia-Pacific born Australians has increased over the past three decades and is projected to increase further during the next two decades.<sup>18</sup>

### New Zealand

Recent conservative figures estimate 67,000 people in New Zealand (NZ) have CHB infection.<sup>19</sup> The prevalence of HBsAg among 177,000 participants in the successful NZ Hepatitis B Screening Programme was 5.6% for Maori, 7.3% for Pacific Islanders, 6.2% for Asian and 0.43% for New Zealanders of European extraction. Men were more likely to test HBsAg-positive (6.1%) than women (5.4%).<sup>20</sup> HBV DNA was detected in 30-40% of HBeAg-negative patients with persistently elevated enzymes. HBV related morbidity is similar to that in Australia.<sup>21,22</sup>

## 2 SCREENING IN HIGH-RISK GROUPS

**There is a clear need for targeted screening for HBV infection in individuals from high-risk groups. CHB infection acquired at birth or in early childhood usually remains an asymptomatic disease until late in life when liver failure or liver cancer can develop in up to 40% of cases.**

Individuals migrating from high-prevalence countries have the same rates of infection as that of their birth country, for example Vietnamese or Chinese migrants living in Australia have an 8-10% prevalence of CHB infection.

**Table 1** lists the groups at higher risk of infection who should be screened for HBV infection.<sup>(III)</sup><sup>23</sup>

Studies in Australia<sup>24</sup> and the US<sup>25</sup> demonstrate between 30-65% of chronically infected adults are unaware they are infected until they were screened. Given the high prevalence of unrecognised CHB infection, it is paramount that health care providers routinely screen for infection in at risk groups.

Identification of HBV infection in the asymptomatic phase has become an effective strategy. Therapy and cancer surveillance have both been shown to improve outcomes in selected patients. Modelling in the US has established the cost effectiveness of screening high-risk patients.<sup>26</sup> Importantly, there is also likely to be a benefit to the wider community as infected individuals can be educated about their infectivity, at risk contacts can be offered vaccination, and potentially, transmission can be reduced.

**Table 1: Groups at High Risk for HBV Infection**

<p><b>Persons born in hyperendemic areas</b></p>	<p>Individuals born in areas of high<sup>a</sup> and intermediate prevalence rates<sup>b</sup> for HBV including immigrants and adopted children:<sup>c,d</sup></p> <p><b>Asia:</b> All countries (except Sri Lanka)</p> <p><b>Africa:</b> All countries</p> <p><b>South Pacific Islands:</b> All countries and territories</p> <p><b>Middle East:</b> All countries (except Cyprus)</p> <p><b>Western Europe:</b> Greece, Italy, Malta, Portugal, and Spain</p> <p><b>Eastern Europe:</b> all countries (except Hungary)</p> <p><b>The Arctic:</b> indigenous populations</p> <p><b>South America:</b> Argentina, Bolivia, Brazil, Ecuador, Guyana, Suriname, Venezuela, and Amazon region of Colombia and Peru</p> <p><b>Central America:</b> Belize, Guatemala, Honduras, and Panama</p> <p><b>Caribbean:</b> Antigua and Barbuda, Dominica, Dominican Republic, Grenada, Haiti, Jamaica, Puerto Rico, St. Kitts and Nevis, St. Lucia, St. Vincent and Grenadines, Trinidad and Tobago, and Turks and Caico</p>
<p><b>Other high risk groups</b></p>	<p>All patients undergoing chemo- or immuno-suppressive therapy</p> <p>Indigenous populations<sup>d</sup></p> <p>Household contact with someone diagnosed with CHB<sup>d</sup></p> <p>Injecting drug used</p> <p>Men who have sex with men<sup>d</sup></p> <p>Inmates of correctional facilities<sup>d</sup></p> <p>Infected with hepatitis C virus (HCV) or HIV<sup>d</sup></p> <p>Patients undergoing renal dialysis<sup>d</sup></p>

a HBsAg prevalence >8% ; b HBsAg prevalence 2 to 7%; c If HBsAg-positive persons are found in the first generation, subsequent generations should be tested; d Those who are seronegative should receive hepatitis B vaccine

### 3 NATURAL HISTORY

**Hepatitis B is an immune-based disorder in which the extent of disease as well as the frequency and quality of virologic response are profoundly influenced by the depth of the host immunologic response.<sup>27</sup> The immunologic interface between the host and the replicating virus also determines the extent to which liver disease becomes evident.**

#### Acute HBV

Acute hepatitis B develops 6-12 weeks following exposure to the virus and is marked by serological and biochemical evidence of infection. HBV related symptoms are rare in the perinatal setting but relatively common in adult-acquired infection. Mortality from development of acute liver failure occurs in <1% of cases.

Acute HBV infection has variable outcomes. Depending on the interactions among several virus and host-related variables, complete recovery with development of anti-HBV immunity may occur or acute infection may evolve into chronic infection.<sup>28-31</sup> Progression to chronic infection varies from 90% among perinatally exposed (and unvaccinated) infants, to 30% among children age under 5 years, to <5% for adults.

Using sensitive assays, HBV DNA can be detected in liver tissue up to 10 years after 'recovery' from an acute HBV infection.<sup>32,33</sup> This may account for immunosuppressive therapy-induced reactivation of HBV replication in persons with serological markers of resolved HBV infection.<sup>34,35</sup>

#### Progression to Chronic HBV Infection

CHB is defined as persistent detection of HBsAg for >6 months after initial exposure to the virus. The natural history of CHB can be categorised into four successive phases of variable duration (**Figure 1**). To determine the phase of CHB in an individual both hepatic and viral factors are considered.

##### Phase 1 - Immune Tolerance

This early phase is characterised by normal serum ALT levels despite the presence of hepatitis B e antigen (HBeAg) and HBV DNA in serum, indicating a lack of host immune response against

HBV infected hepatocytes.<sup>28-31</sup> Spontaneous and treatment-induced HBeAg seroconversion is infrequent (<5% per year). In those who remain in this phase, disease progression appears to be minimal. However, immune-tolerant patients will at some point progress to the immune clearance phase and may experience disease progression.<sup>36</sup>

##### Phase 2 - Immune Clearance

The immune clearance phase is characterised by persistently or intermittently elevated ALT levels, fluctuating viral loads and moderate-to-high levels of liver inflammation. The factors that lead to loss of immune tolerance and the development of an active host immune response against infected hepatocytes are unclear. Rapid progression of liver disease can occur during this phase.<sup>28-31</sup>

In some cases the host immune response will result in seroconversion of HBeAg to anti-HBe accompanied by a state of non-replicative infection, characterised by low or undetectable serum HBV DNA and normal ALT levels. The annual rate of spontaneous HBeAg seroconversion is estimated to be approximately 5-15%.<sup>30,37,38</sup> Following HBeAg seroconversion there is a relatively low risk of disease progression. However increasing viraemia and recurrent hepatitis after seroconversion may indicate the development of phase 4 immune escape.

The spontaneous development of anti-HBs and clearance of HBsAg occurs annually in 0.5-2% of people with CHB in western countries. Clearance of HBsAg signifies resolution of the chronic infection.

##### Phase 3 - Immune Control

This phase is characterised by persistent HBV infection without significant necroinflammatory disease.<sup>30</sup> Immune control is associated with undetectable to low levels of HBV DNA, persistently normal liver enzymes and low risk of progressive disease. Individuals in this category need to be distinguished from those in the immune tolerant phase of infection who have high levels of serum HBV DNA (see **Figure 1**). The inactive replication phase may persist indefinitely. The prognosis is generally favourable, especially if significant liver fibrosis has not occurred prior to an effective host immune response.<sup>39</sup> Reactivation of HBV may occur spontaneously or as a result of immunosuppression.<sup>35,40</sup>

**Figure 1: Natural History and Phases of CHB**

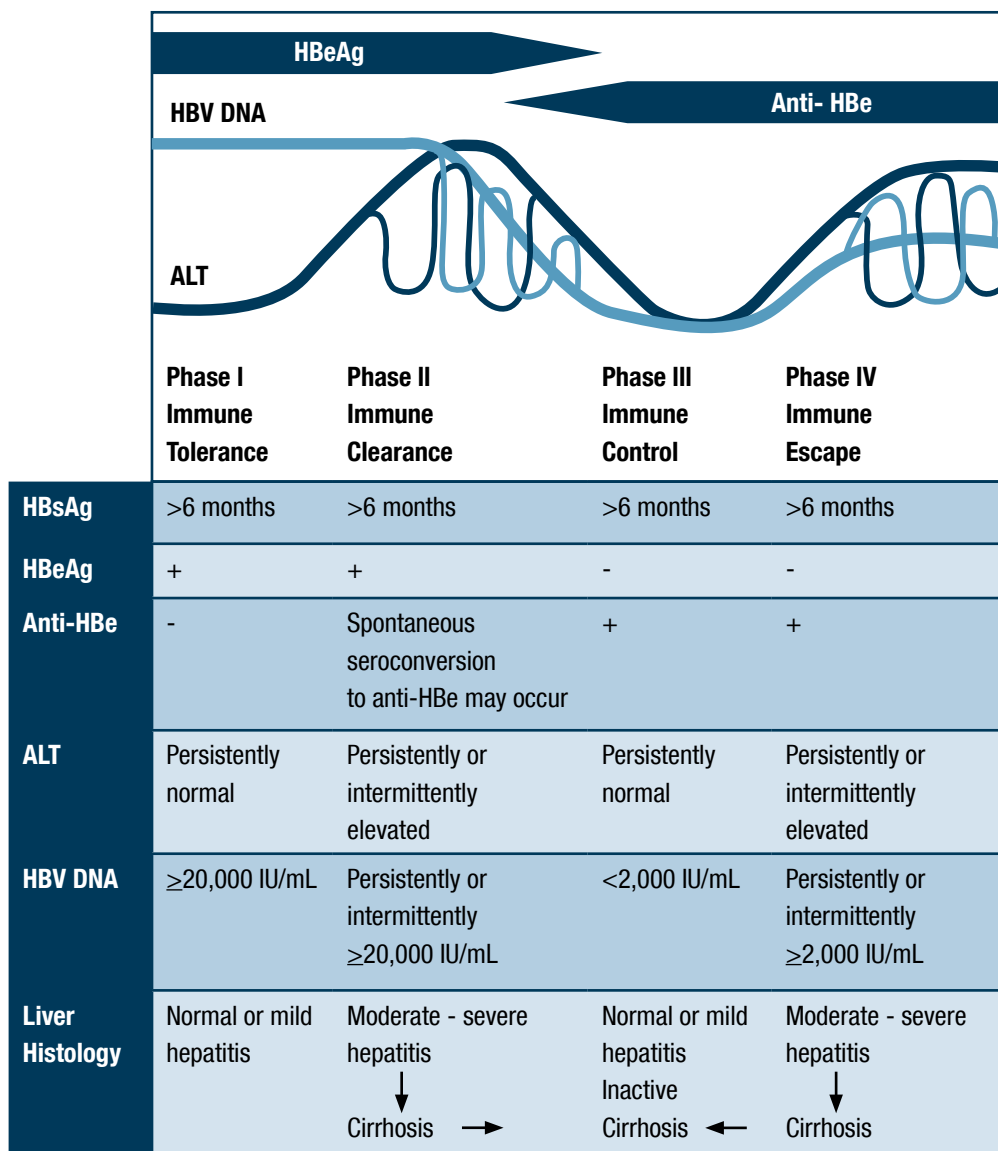

#### Phase 4 - Immune Escape

In this phase a mutant virus that does not secrete HBeAg causes recurrence of active liver disease. This viral mutation emerges late in the course of infection in those initially infected with wild type (HBeAg-positive) virus.<sup>41,42</sup> The prevalence of HBeAg-negative hepatitis varies geographically and is more common in Asia and the Mediterranean region. Infection with HBeAg-negative CHB is associated with a fluctuating course and progressive fibrosis.<sup>43</sup>

Active HBeAg-negative CHB is associated with either persistent ALT elevation or an erratic pattern of ALT changes with “flare-ups” resembling acute hepatitis B that can be severe. Serum HBV DNA levels are usually lower than in HBeAg-positive patients but generally higher than those seen in patients in the immune control phase.

Few patients with HBeAg-negative CHB achieve a lasting remission. HBeAg-negative CHB may escape clinical recognition and liver disease may have progressed to advanced stages of fibrosis, including cirrhosis and even HCC, when reactivations are finally identified.<sup>44,45</sup> Progression to cirrhosis has been estimated to occur in 8-10% of people with HBeAg-negative CHB each year.

#### Disease Progression

Although the pathogenesis of CHB-associated liver injury is complex, chronic intrahepatic replication of HBV results in an ongoing cascade of inflammation, injury, and repair. Without resolution, this inflammatory cycle leads to scarring and fibrosis - ending in cirrhosis and loss of hepatic function - and to uncontrolled hepatocyte regeneration with the potential for HCC.

## HBV DNA Levels

There is strong evidence to show the serum level of HBV DNA is the major clinical feature related to liver disease progression.<sup>46, 47</sup>

The Risk Evaluation of Viral Load Elevation and Associated Liver Disease/Cancer - HBV (REVEAL-HBV) study found that serum HBV DNA levels across a biological gradient are strongly predictive of the risk of disease progression and remain a strong predictor after accounting for other factors such as HBeAg, serum ALT and liver cirrhosis.<sup>48, 49</sup> In this community based survey, Taiwanese patients were aged between 30-65 years at enrolment. The development of HCC was 10 times greater in patients with persistent HBV DNA >20,000 IU/mL than in those with levels <2,000 IU/mL at enrolment. However, even when HBV DNA levels decreased from 20,000 to 2,000 IU/mL, there was still a substantial risk for HCC development. Cirrhosis incidence rates showed a similar correlation with HBV DNA levels. The relative risk of developing cirrhosis was significantly elevated for those with HBV DNA levels as low as 2,000 IU/mL and was sixfold greater for those with HBV DNA  $\geq$ 200,000 IU/mL at enrolment.

Similar outcomes were found in a cohort of 70 untreated Caucasian patients with HBeAg-positive CHB followed for 25 years.<sup>46</sup> The risk of liver-related death was strongly associated with sustained disease activity and a high level of HBV replication (HBV DNA level), independently of HBeAg status. Older age, male sex, and cirrhosis at study entry were also independently associated with an increased risk of mortality.

Even persistent low level viraemia may be associated with liver damage independently from factors such as HBeAg status and baseline ALT levels.<sup>48-50</sup> Patients with ALT levels within the normal range are at risk for the development of cirrhosis and HCC if HBV DNA levels are higher than 2,000 IU/mL.

## ALT Levels

Prolonged ALT level elevation also indicates liver injury and disease progression.<sup>51</sup> A large prospective cohort study indicated even people with slightly increased ALT activity, but still within the normal range, should be closely observed and further investigated for liver diseases.<sup>54</sup>

Other studies show patients with low-normal or high-normal ALT levels (0.5-1 times the upper limit of normal [ULN]) are at risk of developing complications of liver disease.<sup>52, 53</sup> Compared with those individuals with an ALT of less than 20 IU/L, those with ALT levels of 20–29 had a relative risk of mortality of 2.9, and those with an ALT level of 30–39 had a relative risk of mortality of 9.5.<sup>54</sup> Thus, some studies are suggesting an ULN for ALT and AST of 30 IU/L for men and 19 IU/L for women. These findings are likely to increase the number of CHB patients that will require long term monitoring for disease progression and will also influence treatment recommendations.

## Other Factors

Host and viral risk factors associated with increased rates of cirrhosis and / or HCC include:<sup>28, 55-57</sup>

- Older age (longer duration of infection)
- Habitual alcohol consumption
- Co-infection with hepatitis C virus (HCV), hepatitis D virus (HDV) or human immunodeficiency virus (HIV)
- Carcinogens such as aflatoxin and tobacco
- Male gender
- Family history of HCC
- History of reversion from anti-HBe to HBeAg
- Presence of cirrhosis
- HBV genotype C
- Core promoter mutation

## Improving Outcomes

**Ideally, CHB patients should have HBV DNA levels <2,000 IU/mL with ALT levels within the normal range.(II-1) Early detection and prolonged, adequate suppression of viral replication should be the practical goal for the management of CHB.<sup>49</sup>**

## 4 RECOMMENDATIONS FOR PATIENT EVALUATION

### Diagnosis

HBV infection is confirmed by the detection of hepatitis B surface antigen (HBsAg) or HBV DNA in serum. In addition to patient exposure history, serology can assist in determining whether infections are newly acquired or chronic.

Diagnosis of newly acquired infections requires one of the following:

- HBsAg in a patient shown to be negative within the last 24 months
- HBsAg and high levels of specific IgM to hepatitis B core antigen (HBcIgM) in the absence of prior evidence of HBV infection
- HBV DNA and high levels of specific IgM to hepatitis B core antigen (HBcIgM) in the absence of prior evidence of HBV infection

Diagnosis of chronic infection requires:

- Detection of HBsAg or HBV DNA (PCR) in the serum of a patient on two occasions at least six months apart
- No clinical or laboratory evidence of acute hepatitis B

### Baseline Evaluation

The initial evaluation of patients with CHB should include a thorough history and physical examination, with special emphasis on risk factors for co-infection, alcohol use, and family history of HBV infection and liver cancer.(III)

**Table 2** summarises the tests that should be performed at the initial evaluation of patients with CHB.

## 5 CHB TREATMENT GOALS AND OBJECTIVES

### Treatment Goal

The primary goal is to improve patient survival by preventing or delaying the development of cirrhosis and hepatocellular carcinoma.<sup>30</sup>

### Treatment Objectives

The key treatment objectives are:(II-2, III)<sup>4, 58-62</sup>

- HBV DNA suppression (<2,000 IU/mL; PCR undetectable <60 IU/mL)
- HBsAg loss and seroconversion
- HBeAg loss and seroconversion
- Biochemical and histological improvement

As the eradication of HBV infection is not achievable with currently available therapy, the primary aim of treatment is to maintain HBV DNA suppression (<2,000 IU/mL) in order to prevent progressive liver injury.<sup>4, 58-60</sup> Prolonged viral suppression is associated with reduction in necroinflammation, fibrosis, and cirrhosis. Other favorable outcomes associated with suppression of HBV replication include reduced decompensation of underlying liver disease, reduced rates of hepatocellular carcinoma in patients with CHB, and ultimately reduced mortality.

### HBsAg Clearance

Loss of HBsAg and seroconversion to anti-HBs is considered a complete response and is durable in most cases. However, loss of HBsAg is not common after therapy, occurring in 3-8% of patients receiving IFN<sup>63-67</sup> and <5% of patients receiving nucleoside/nucleotide analogue therapy.<sup>68-74</sup>

**Table 2: Initial Evaluation**

History and physical examination.

#### Laboratory testing and imaging studies:

Liver function tests, full blood examination, INR

HBeAg/anti-HBe, HBV DNA (quantitative viral load)

Test for HBV genotype (if available)

HCV antibody, hepatitis D virus antibody and antigen,<sup>≠</sup> HIV antibody

Total antibody to hepatitis A virus; vaccinate if no immunity(II)

Alfa-fetoprotein (FP) and abdominal ultrasound to screen for HCC\*

Consider gastroscopy to look for oesophageal varices if clinical, laboratory or imaging evidence of cirrhosis.

Liver biopsy is strongly recommended prior to initiating antiviral therapy.

<sup>≠</sup>In selected patients from the Pacific Islands, Mediterranean, parts of South America and Africa \*Biopsy may be particularly helpful in patients older than 35-40 years of age with normal ALT levels

## HBeAg Clearance

Loss of HBeAg and seroconversion to anti-HBe is associated with decreased viral replication and improved liver histology. Seroreversion to detectable HBeAg following treatment has been reported in 10-30% of patients following interferon therapy<sup>75-78</sup> and up to 60% after nucleoside/nucleotide analogue therapy, particularly if treatment is stopped soon after HBeAg becomes undetectable.<sup>79</sup> Furthermore, some patients may evolve into HBeAg-negative CHB.<sup>42</sup>

## Patients to Treat

Treatment is always an individual decision based on treating patients who are at risk for the development of cirrhosis and its consequences, liver failure and HCC.

The decision to treat requires consideration of several factors which have been identified as indicating risk of adverse outcomes including HBV DNA, ALT levels, patient age, extent of histological fibrosis or inflammation and clinical or imaging evidence of cirrhosis (**Table 3**).<sup>47-49, 51, 80, 81</sup>

In addition to clinical parameters it is crucial to incorporate patients' wishes, anticipated compliance and consideration of any contra-indications to treatment.

Most patients require a long duration of treatment to derive continued clinical benefit. As treatment may be required for years, decades, or the duration of the patient's life, the decision to initiate treatment must balance the long-term benefits vs. the long-term risks.

**Table 3: Clinical Considerations for Treatment**

	HBeAg Status	HBA DNA (IU/mL)	ALT Levels	Liver Histology* (most common findings)	Treatment
Immune Tolerance	Positive	≥20,000	Persistently normal	Normal or mild inflammation No fibrosis	No treatment
Immune Clearance	Positive	≥20,000	Minimally elevated (1-2 x ULN)	Usually minimal inflammation, variable fibrosis.	Consider biopsy if age >40 years and treat if significant hepatic fibrosis (>F2) or moderate to severe inflammation
Immune Clearance	Positive	≥20,000	Persistently or intermittently elevated (>2 x ULN)	Moderate to severe chronic hepatitis with active inflammation and variable fibrosis	If HBeAg seroconversion does not occur spontaneously within 3-6 months, consider liver biopsy and treatment
Immune Control	Negative	≤2,000	Persistently normal	Mild Inflammation No fibrosis	No treatment
Immune Escape	Negative	≥2,000	Minimally elevated (1-2 x ULN)	Usually minimal inflammation, variable fibrosis.	Consider biopsy if age >40 years and treat if significant hepatic fibrosis (>F2) or if clinical signs of advanced disease without biopsy
Immune Escape	Negative	≥2,000	Persistently or intermittently elevated (>2 x ULN)	Moderate to severe chronic hepatitis with active inflammation and variable fibrosis	Consider liver biopsy and treatment

## Treatment Options

Approved first and second line therapies for CHB in Australia and New Zealand are listed in **Table 4**.

**Table 4: Classification of CHB treatments and Current Indications**

Drug Class	Chemical Classification	Name	Current Indications Australia	Current Indications New Zealand
Nucleoside analogues	Pyrimidine base	Lamivudine (LAM)	Children (2 years and above), adolescent and adult patients with CHB and evidence of HBV replication. <sup>a</sup>	In patients with evidence of HBV replication.
		Telbivudine (LdT)	HBeAg-positive and HBeAg-negative CHB patients who have compensated liver disease, evidence of viral replication and active liver inflammation and who are nucleoside analogue naïve.	In patients with evidence of viral replication and active liver inflammation. <sup>d</sup>
	Purine base	Entecavir (ETV)	Adults 16 years or older with evidence of active liver inflammation. <sup>b</sup>	Adults with evidence of active liver inflammation.
Nucleotide analogues	Acyclic phosphonate	Adefovir (ADV)	Adults with evidence of active viral replication and either evidence of persistent elevations in ALT or AST or histologically active disease. <sup>c</sup>	Patients 16 years and older with evidence of hepatitis B viral replication. <sup>e</sup>
		Tenofovir (TDF)	Adults with evidence of active viral replication and active liver inflammation.	Adults.
Cytokines		Pegylated Interferon (pegIFN)	Adults with evidence of viral replication and liver inflammation and compensated liver disease.	HBeAg-positive and HBeAg-negative CHB in non-cirrhotic and cirrhotic patients with compensated liver disease and evidence of viral replication and liver inflammation.

This indication is based on:

- serological and histological markers in clinical studies of up to 2 years duration in adult patients with compensated liver disease and serological data up to 18 months in children and adolescents. Children and adolescents also require evidence of active hepatic inflammation.
- Histologic, virologic, biochemical and serological responses after 48 weeks of treatment in nucleoside-treatment naïve and lamivudine-resistant adult patients with HBeAg-positive or HBeAg-negative CHB with compensated liver disease. Safety and efficacy have not currently been demonstrated for treatment periods longer than 48 weeks.
- Histological, virological, biochemical, and serological responses in adult patients with HBeAg+ and HBeAg-/HBVDNA+ CHB with compensated liver function, and in adults patients with clinical evidence of lamivudine-resistant HBV with either compensated or decompensated liver function.
- Virological, serological, biochemical and histological responses after one year of treatment in adult patients with HBeAg-positive and HBeAg-negative chronic hepatitis B.
- Histological, virological, biochemical, and serological responses in adult patients with HBeAg+ and HBeAg-/HBVDNA+ CHB with compensated liver function, and in adults patients with clinical evidence of lamivudine-resistant hepatitis B virus with either compensated or decompensated liver function.

## Nucleoside/Nucleotide Analogues

Nucleoside/nucleotide analogues act as competitive inhibitors of HBV reverse transcriptase/DNA polymerase to prevent the incorporation of natural nucleosides leading to chain termination. Currently five agents have been approved for treatment of CHB: lamivudine, entecavir, telbivudine, adefovir and tenofovir. They are effective agents for all patients and have particular use in subgroups who may not tolerate pegIFN e.g. patients with decompensated liver disease, during pregnancy, viral co-infections, immunosuppression and in solid organ (including liver) and stem cell transplantation. As with pegIFN, individuals with high ALT levels are more likely to achieve HBeAg seroconversion. Overall nucleoside / nucleotide analogues lead to loss of HBeAg in a similar proportion of treated patients as interferon although treatment duration to achieve this outcome varies.

Drug resistance is common with first generation agents, with rates of resistance occurring in up to 70% of lamivudine-treated patients after 5 years.<sup>82</sup> The newest agents – tenofovir and entecavir – have favourable resistance profiles. Entecavir has a low resistance profile in naïve patients, but is high in patients with existing lamivudine resistance due to cross-resistance. Evidence suggests tenofovir has an excellent resistance profile in all patients regardless of previous therapy (see: **9 Managing Antiviral Resistance**).

Nucleoside/nucleotide analogues are well tolerated and discontinuation due to adverse events is rare. The potential development of lactic acidosis associated with hepatomegaly and steatosis is rare but can occur with all of the currently available agents.

Hepatic function should be monitored closely in patients who discontinue treatment as some patients may develop a severe acute exacerbation of hepatitis.

All oral antiviral agents require dose reduction in the setting of renal insufficiency and dose adjustments according to creatinine clearance. Adefovir and tenofovir have been associated with dose-dependent renal toxicity and may result in serum creatinine elevation. However, after 96 weeks treatment, only 2% of patients treated with adefovir 10mg daily had an elevation in

serum creatinine of >0.5 mg/dL by Kaplan-Meier analysis.<sup>83, 84</sup> In patients with normal baseline renal function, there is minimal concern regarding nephrotoxicity with the use of adefovir (10mg daily).

In a longterm multicentre evaluation of tenofovir, one patient showed mild creatinine elevation at 12 months. In all other patients creatinine levels remained in the normal range.<sup>85</sup>

## Interferons

The interferons act as immunomodulators and promote an antiviral state that inhibits viral replication. In Australia and NZ, pegylated interferon (pegIFN) has replaced standard interferon in CHB therapy.

The benefits of pegIFN are the lack of antiviral resistance, a defined duration of therapy (48 weeks), HBeAg seroconversion in 30% of patients and loss of HBsAg in 5-8%.<sup>64, 66</sup>

The best candidates for pegIFN are those who meet the following criteria:

- An active host immune response to HBV characterised by:
  - Serum ALT levels >2 x ULN
  - HBV DNA levels <8 log IU/mL
- Those who wish to avoid long term treatment, such as young person's planning a family

The adverse effects of pegIFN include myalgias, arthralgias, and flu-like symptoms, such as fever and chills. These symptoms typically occur within the first month of therapy and subside during the course of therapy.<sup>86, 87</sup> PegIFN may exacerbate underlying autoimmune conditions and may worsen neuropsychiatric disorders, particularly depression. Neutropenia and thrombocytopenia due to interferon induced bone marrow suppression are common and require regular monitoring. Less common adverse events include hypothyroidism, cardiac and retinal toxicity.

The immunomodulatory effect of interferon can cause severe exacerbations of hepatic inflammation (ALT flares) in patients treated with either standard or pegIFN, including hepatic decompensation in patients with cirrhosis.<sup>88</sup> In clinical trials, neutropenia was the most common reason for dose reduction or early discontinuation, events that were both more common in patients with cirrhosis.<sup>87</sup> Interferons are contraindicated in patients with decompensated cirrhosis.

Table 5 summarises the advantages and disadvantages of CHB treatment options.

Table 5: Overall Advantages and Disadvantages of Treatments for CHB		
	pegIFN	Nucleosides / Nucleotides
<b>Advantages</b>	Defined treatment duration	Easy to administer and monitor
	No antiviral resistance	Safe in patients with cirrhosis / decompensated liver disease
	Durability of HBeAg seroconversion	Few, if any, side effects
<b>Disadvantages</b>	Subcutaneous administration	Generally prolonged duration of therapy
	Significant side effects	Antiviral resistance is common with some agents with prolonged therapy
	Contraindicated in Child's B + C cirrhosis	
	No more effective than placebo in patients with high HBV DNA and low ALT levels	

## 6 MONITORING ON AND OFF-TREATMENT RESPONSE

### Not Currently Receiving Treatment

Patients in whom antiviral treatment is not currently indicated or who have declined therapy still require continued monitoring. Table 6 outlines suggested monitoring for patients who are not treatment candidates.(II)

Not all patients with CHB are at equal risk of developing HCC. Surveillance should be performed every six months using abdominal ultrasound and serum alpha foetoprotein in those at high risk for hepatoma, including those with cirrhosis, a family history of HCC, active inflammation on liver biopsy, Africans older than 20 years, Asians older than 35 years (if infected early in life).

Table 6: Suggested Evaluation for Patients who are NOT Treatment Candidates	
Immune Tolerance Phase	Immune Control Phase
<p><b>If ALT levels &lt;2 x ULN</b></p> <p>HBeAg and liver function tests every 12 months</p> <p><b>If ALT levels increase to &gt;2 x ULN</b></p> <p>increase monitoring frequency to 3-6 monthly</p> <p>Consider liver biopsy and treatment if ALT levels are persistently &gt;2 x ULN and if HBeAg seroconversion does not occur within 6 months.</p> <p>For patients over age 40 years with ALT elevations 1-2 x ULN, consider biopsy and treatment.</p>	<p>HBV DNA and liver function tests every 12 months.</p> <p>If ALT levels increase, check serum HBV DNA and exclude other possible causes of ALT elevation.</p> <p>Consider liver biopsy and treatment if HBV DNA &gt;2,000 IU/mL; ALT remains elevated and no other cause found and / or if liver biopsy shows significant fibrosis.</p>
Consider HCC screening in high risk patients	

## Treatment with Nucleoside / Nucleotide Analogues

### Primary Treatment Response

On-treatment monitoring strategies to define early virologic responses appear to be predictive of better outcomes and a reduced risk of viral resistance.<sup>89</sup> Several studies have already shown that an initial virologic response is associated with lower rates of antiviral drug resistance in the long-term.<sup>90-92</sup>

Primary treatment failure (defined as <1 log decrease in serum HBV DNA at treatment week 12) is uncommon. Non-responders (HBeAg-positive and -negative) should be identified to maximise long-term treatment efficacy. If the patient has been noncompliant, compliance should be emphasised and the patient followed closely. If compliant, the optimal strategy is to add a second agent to avoid resistance (Figure 2).<sup>74, 89, 93-95</sup>

Measurement of the HBV DNA level at treatment week 24-48 characterises virologic responses as complete, adequate/partial, or sub-optimal.<sup>89</sup>

In Figure 2 an ideal virologic response is defined as negative HBV DNA by a sensitive assay (<60 IU/mL); HBV DNA levels 60-2,000 IU/mL equate to an adequate virologic response, and HBV DNA levels >2,000 IU/mL indicate a sub-optimal virologic response. The antiviral response at week 24 of therapy was also found to be a predictor of resistance in patients treated with lamivudine and telbivudine.<sup>96</sup> Week 48 may be used for predicting resistance to adefovir therapy.<sup>93</sup>

Individual strategies are proposed for managing patients in each of these categories, depending in part on the rapidity with which HBV DNA suppression is achieved and the emergence of genotypic mutations that reduce the effectiveness of a specific drug. In a patient with a sub-optimal response disease progression and viral resistance are more common and thus therapy should be changed to a more potent drug or a second agent should be added, preferably one without cross-resistance.<sup>89</sup>

Figure 2: Monitoring Virological Response and Breakthrough<sup>89</sup>

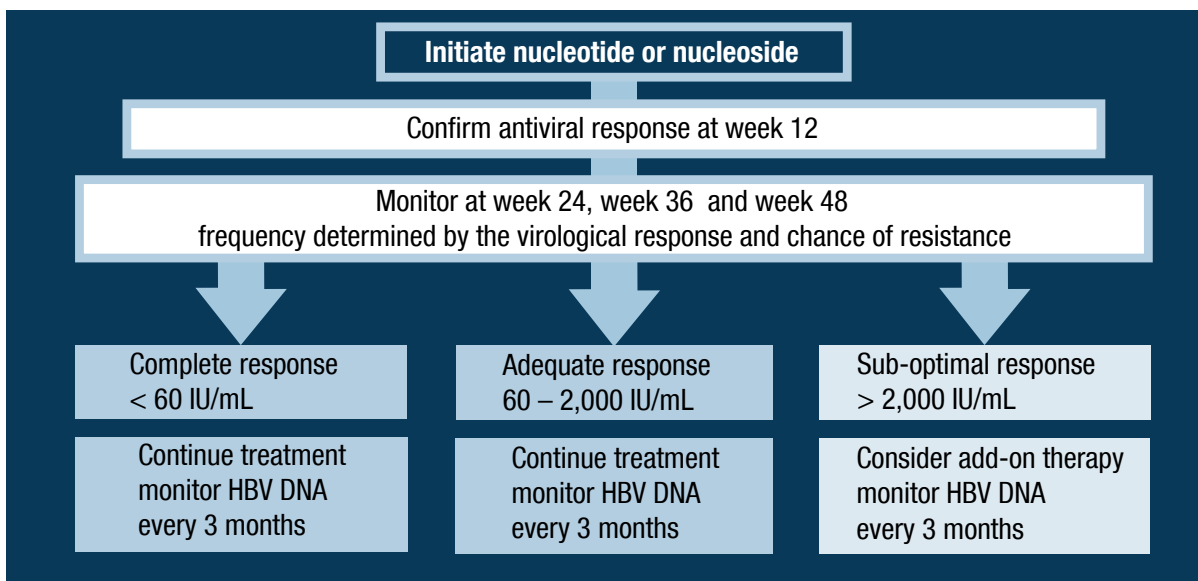

Adapted from Keeffe 2007.<sup>89</sup>

## On-Treatment Responses

During treatment all patients should be closely monitored for virological and biochemical breakthrough (see: **9 Managing Antiviral Resistance**). Virological breakthrough (defined as  $\geq 1 \log_{10}$  increase of HBV DNA above nadir documented in two consecutive samples one month apart) indicates virological resistance or poor compliance. Biochemical breakthrough (defined as ALT elevations  $> 2 \times$  ULN, during treatment after prior normalisation in a compliant patient) indicates clinical resistance in a patient with genotypic resistance. Other causes for ALT increase should be excluded.

## Laboratory Testing

<b>Baseline</b>	<b>Full blood examination (FBE):</b> Haemoglobin, leukocytes, platelet count. <b>Liver function tests (LFT):</b> ALT, ALP, bilirubin, albumin. <b>Virology:</b> HBsAg, HBeAg, anti-HBe, HBV DNA Serum creatinine
<b>Post- 1 month</b>	LFT, HBV DNA
<b>Post- 3 month (and then every third month)</b>	FBE, LFT, HBV DNA, HBeAg/anti-HBe (for HBeAg-positive patients) Serum creatinine Analysis for possible resistance mutations if virological breakthrough
<b>End of Treatment and 3, 6, 12 months after the end of treatment</b>	FBE, LFT, HBsAg, HBeAg, anti-HBe, HBV DNA

## Duration of Treatment

Nucleoside analogue treatment of HBeAg-positive patients should be continued for at least 6-12 months following HBeAg seroconversion.

There are no agreed treatment endpoints for HBeAg negative patients and continued treatment is recommended, in particular in patients with severe liver damage.

Treatment can be discontinued in patients who achieve seroconversion for HBsAg to anti-HBs.

In patients who develop viral resistance, the treatment regimen should be modified (see: **9 Managing Antiviral Resistance** and **12 Combination & Dual Therapy Strategies**).

In some cases discontinuation of treatment may be justified, but this is not an option for patients with severe or decompensated liver disease due to the risk of severe hepatic flares.

## Treatment with PegIFN

Patients treated with pegIFN should be monitored closely. Liver tests and a full blood examination should be performed at monthly intervals.

### Primary Treatment Response

Currently there are few data to guide treatment based on virological response during therapy. Virological responses following week 4 may be associated with better end of treatment outcomes than early responses.<sup>97</sup> Until such data are available, a defined treatment duration will be applicable to all patients, both HBeAg positive and HBeAg negative, with responses determined following the end of therapy.

### Laboratory Testing

<b>Baseline</b>	<b>Full blood examination (FBE):</b> Haemoglobin, leukocytes including neutrophil count, platelets. <b>Liver function tests (LFT):</b> ALT, ALP, bilirubin, albumin. <b>Virology:</b> HBsAg, HBeAg, anti-HBe, HBV DNA
<b>Every Month</b>	FBE and LFT
<b>Every 3 Months</b>	HBV DNA, HBeAg/anti-HBe (HBeAg-positive patients) Thyroid stimulating hormone
<b>End of Treatment and 1,3 and 6 months after the end of treatment</b>	FBE and LFT
<b>Every 3- 6 months after end of treatment for 12 to 18 months</b>	HBsAg, HBeAg, anti-HBe, HBV DNA

### End of Treatment Responses

There is no widely accepted definition for an end of treatment response. Ideally, HBV DNA would be undetectable at the end of treatment. However, based on clinical trial definitions, a successful outcome for HBeAg positive patients is defined as anti-HBe-positive with a normal ALT level for more than six months, with HBV DNA <20,000 IU/mL.<sup>65</sup> A similar definition (without HBeAg determination) applies for HBeAg negative patients.<sup>66</sup>

### Duration of Treatment

The current duration of pegIFN therapy is 48 weeks. Therapy is stopped prematurely only if intolerable adverse effects develop.

Post-therapy, HBsAg, HBeAg, HBV DNA and ALT levels should be monitored every 12 months annually until HBsAg seroconversion occurs or an alternative therapy regimen is commenced.

## 7 TREATMENT OF HBeAg-POSITIVE CHB

### First Line Treatment Options

Treatment with a nucleoside/nucleotide analogue or pegIFN is appropriate. Patient age, severity of liver disease and tolerance for adverse events are factors that may influence the agent used.

A potent drug with a high genetic barrier should be chosen. Tenofovir, entecavir and pegIFN are preferred as first-line therapy for treatment of naïve patients with HBeAg-positive disease. Adefovir is also appropriate. Lamivudine and telbivudine are not recommended due to higher resistance rates.<sup>(I)</sup><sup>65, 70, 74</sup> **Figure 3** shows the treatment algorithm for HBeAg-positive CHB.

Suppression of viral replication is indicated by HBeAg loss with seroconversion to anti-HBe as well as non-detectable HBV DNA by PCR. Viral suppression without HBeAg seroconversion is invariably associated with relapse, whereas HBeAg seroconversion is associated with durable responses in 50-90% of patients. Virologic response is often accompanied by biochemical and histologic improvement.

**Figure 3: Algorithm for HBeAg-positive CHB**

#### Treatment Considerations:

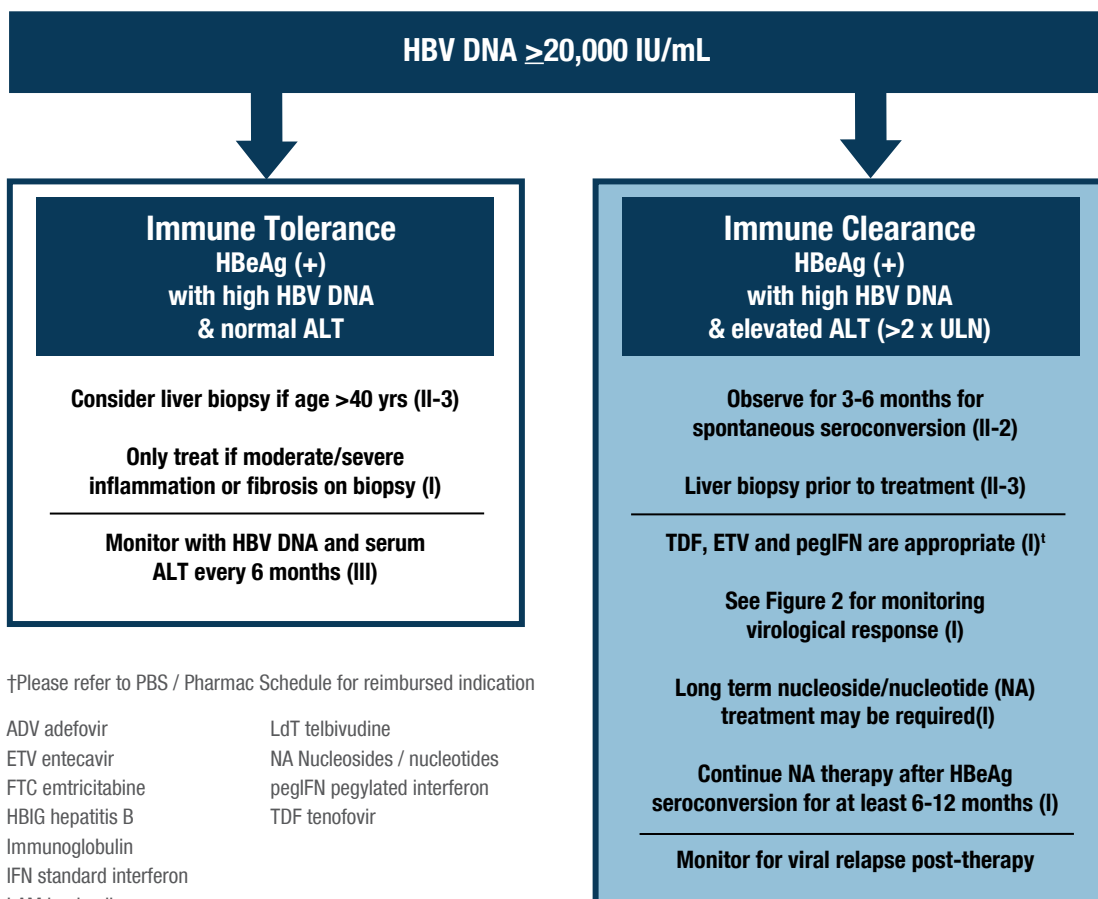

#### Categorisation by Serum ALT Levels

HBeAg positive patients with persistently normal serum ALT and HBV DNA levels  $>20,000$  IU/mL should be monitored with 6 monthly serum ALT and HBV DNA levels.**(III)** An exception is HBeAg-positive patients who are  $>40$  years old with normal or mildly elevated serum ALT levels (1-2 x ULN); these patients should be strongly considered for liver biopsy.**(II-3)** and antiviral treatment if the liver biopsy shows moderate/severe inflammation or significant fibrosis.**(I)**

HBeAg positive patients with persistent or intermittent serum ALT elevation ( $>2$  x ULN) should be observed for 3-6 months for spontaneous HBeAg seroconversion.**(II-2)** Therapy should be considered in patients who do not undergo spontaneous HBeAg seroconversion if serum ALT remains elevated.**(III)** Liver biopsy is strongly recommended before initiating treatment to determine the degree of liver inflammation and fibrosis.**(II-3)**

Patients with jaundice or evidence of decompensation should be treated without delay.

**Figure 4: Percentage of Patients with Undetectable HBV DNA After One Year of Treatment**

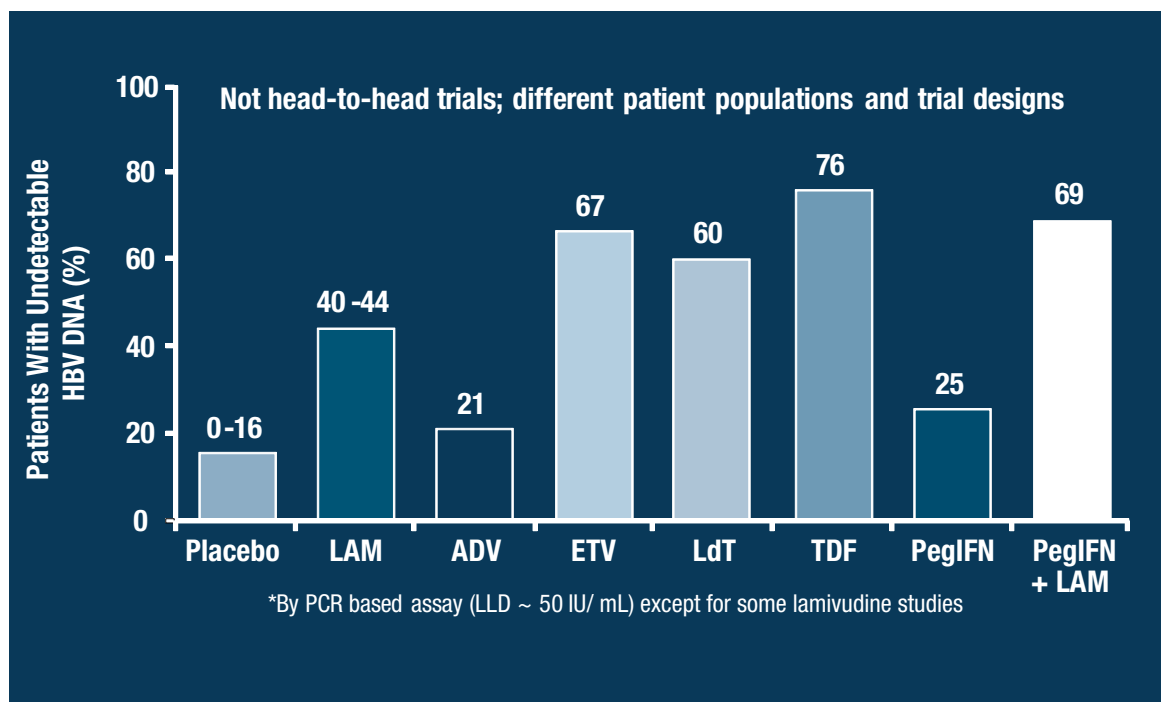

ADV, adefovir; ETV, entecavir; HBeAg, hepatitis B e antigen; LAM, lamivudine; LdT, telbivudine; LLD, lower level of detection; TDF, tenofovir disoproxil fumarate; PegIFN, peginterferon; PCR, polymerase chain reaction.

**Table 7: Summary of Efficacy Data with Treatments**

	Duration of Treatment	HBeAg Seroconversion Rate (%)	Patients with HBV DNA undetectability (at one year) (%)*
<b>PegIFN</b>	48 weeks	27	37
<b>Lamivudine</b>	One year	18	40-44
	Three year	40	
<b>Adefovir</b>	One year	18	21
	Three year	43	
<b>Entecavir</b>	One year	21	67
	Three year	39	
<b>Telbivudine</b>	One year	22	60
	Three year	33	
<b>Tenofovir</b>	One year	21	76
	Three year	NA	

Not head-to-head trials; different patient populations and trial designs<sup>23, 95, 98, 99</sup> \*IFN and LAM: hybridization assay; ADV, ETV, and PegIFN: PCR assay.

**Figure 4** and **Table 7** summarise data on HBeAg seroconversion rates and HBV DNA suppression by various agents.<sup>23, 95, 98, 99</sup> These outcomes are not directly comparable as they are not from head to head studies and represent different patient populations and study designs.

## Antiviral Agents in HBeAg-positive CHB

### pegIFN

HBsAg loss is the hallmark of a complete response to CHB treatment. A large clinical trial of pegIFN-2a in HBeAg positive patients reported a 3% HBsAg seroconversion rate among patients receiving pegIFN either as monotherapy or in combination with lamivudine.<sup>65,66</sup>

Other trials have reported HBsAg seroconversion in 6% of patients treated with pegIFN-2b for one year.<sup>100</sup> In a long-term follow-up study HBsAg loss was observed in 11%.<sup>101</sup> Of those initial responders, sustained HBsAg loss was observed in 30%. The rate of HBsAg clearance was closely linked to viral genotype (14%, 9%, 3%, and 2% for genotypes A, B, C and D, respectively).<sup>100,101</sup> pegIFN leads to the high one-year HBeAg seroconversion rates (**Table 7**).<sup>23,98,99</sup> but lower rates of HBV DNA undetectability compared to nucleoside analogues.<sup>23,98,99</sup>

Patients in the immune clearance phase with elevated pretreatment ALT levels (>2 x ULN) and HBV DNA levels <8 log IU/ml are more likely to respond to interferon than patients in the immune tolerance phase with minimal ALT elevation and high viral loads

### Lamivudine

The rate of HBsAg seroconversion in most lamivudine treatment studies is low and similar to rates of spontaneous seroconversion.<sup>102</sup> Although rare, lamivudine therapy has been shown to result in HBsAg seroclearance in young patients after 24 months use.<sup>102</sup>

HBeAg seroconversion rates can be expected in approximately 18% at one year compared with 4 to 13% of untreated controls.<sup>69,103,104</sup> Higher cumulative HBeAg seroconversion rates are observed with increased duration of lamivudine treatment, 29% at two years, 40% at three years, increasing to 50-70% after five years (**Table 7**).<sup>104-108</sup> Continuation of lamivudine treatment for 6 to 12 months after HBeAg seroconversion appears to decrease relapse rates.

Treatment with the recommended dose, 100 mg once daily, results in a 4-5 log reduction of serum HBV DNA after 52 weeks.<sup>69</sup> HBV DNA undetectability is achieved in 40-44% of patients at one year.<sup>23,98,99</sup>

The prevalence of lamivudine resistance approaches 70% at four/five years (see: **9 Managing Antiviral Resistance**).<sup>82,109</sup>

The emergence of resistance blunts histologic responses and patients may experience worsening liver disease such as hepatic decompensation, and liver-disease-related serious adverse events.<sup>109,110</sup> Therefore, lamivudine is no longer a suitable first-line choice for the treatment of HBeAg-positive CHB, although there are patient subgroups for whom lamivudine should be considered (see: **11 Special Populations**).

Lamivudine therapy results in histologic improvement. In three clinical trials involving a total of 713 naïve patients histologic improvement was observed in 49-56% treated patients and in 23-25% of controls.<sup>68,69,111</sup>

### Adefovir

HBsAg loss or seroconversion is observed in <5% of patients given adefovir for one to two years.<sup>112</sup>

HBeAg seroconversion rates following 12 months treatment have been reported in 18% given adefovir compared to 6% in placebo treated patients (**Table 7**).<sup>23,70,98,99</sup> Patients treated beyond 48 weeks achieved a higher rate of seroconversion and HBeAg loss. At 240 weeks, 58% of adefovir patients had lost HBeAg and 48% had HBeAg seroconversion.<sup>113</sup>

In HBeAg-positive lamivudine resistant patients, rates of HBeAg loss and seroconversion were higher among patients receiving adefovir, either alone or in combination with lamivudine, compared with patients receiving lamivudine monotherapy or placebo.<sup>70,114-116</sup>

Treatment with the recommended dose, 10mg once daily, results in a 3.5-4.05 log reduction of HBV DNA after 48 weeks.<sup>70,113,117</sup> Prolonged treatment of HBeAg-positive patients results in loss of detectable HBV DNA in 21% after one year.<sup>23,70,98,99</sup> The proportion of patients with HBV DNA <200 IU/mL increased to 36%, 38% and 39% at study weeks 144, 192, and 240.<sup>113</sup>

The emergence of resistance mutants occurs in <2% of treated patients after one year of adefovir, gradually increasing to 11% after three years, and between 20-29% after five years.<sup>93,113,118</sup>

Following 48 weeks treatment with adefovir, histological improvement was observed in 53% who received adefovir compared with 25% of those on placebo.<sup>70</sup>

### Entecavir

HBsAg loss or seroconversion was observed in 2% of patients taking entecavir versus 1% receiving lamivudine for a minimum of 52 weeks.<sup>74</sup>

HBeAg seroconversion was reported as 21% after one year and 39% after three years of treatment (**Table 7**).<sup>23, 74, 98, 99</sup> HBeAg seroconversion persists in approximately 80% of patients 24 weeks after withdrawing treatment. However, persistent off-therapy suppression of virus to undetectable levels occurs in only approximately 75% of patients.

At the recommended dose of 0.5 mg once daily for nucleoside naïve patients entecavir is more potent than lamivudine, with entecavir treatment resulting in a 6 log IU/ml reduction of HBV DNA after 48 weeks.<sup>74</sup> Through 96 weeks, entecavir demonstrated superior benefit to lamivudine with 74% of entecavir-treated versus 37% of lamivudine-treated patients achieving undetectable HBV DNA.<sup>119</sup>

The antiviral effect of entecavir is reduced in patients with lamivudine-resistant strains, with only 40% achieving undetectable HBV DNA levels at 96 weeks.<sup>120</sup>

The recommended dose increases to 1 mg once daily for lamivudine-refractory patients.

Emergence of resistant mutants is low (1%) in treatment-naïve patients,<sup>121</sup> but increases to 6% after 1 year and 51% after 5 years if lamivudine resistance is present at the start of treatment.<sup>122</sup>

Treatment through 96 weeks resulted in normalised ALT levels in 79% of entecavir-treated versus 68% of lamivudine-treated patients.<sup>119</sup> When compared to adefovir, there was no significant difference in ALT normalisation after 52 weeks of treatment.<sup>116</sup>

### Telbivudine

HBsAg seroconversion occurred in less than 1% of patients in a trial comparing telbivudine to lamivudine for 52 weeks.<sup>95</sup>

The rate of HBeAg seroconversion at 52 and 104 weeks is comparable to lamivudine and entecavir.<sup>95, 123</sup>

Telbivudine at the recommended dose of 600 mg once daily, reduces HBV DNA by 5-6 log IU/ml after one year of treatment. Undetectable levels of HBV DNA were achieved in 60% after one year of treatment and 54% after two years of treatment (**Table 7**).<sup>95, 123</sup>

Resistant strains have the same mutation pattern as for lamivudine (cross-resistance). Inadequate suppression of the virus is associated with significant rates of development of resistance (4% at year one increasing to 21% at year two).<sup>95, 123</sup>

### Tenofovir

A progressive increase in HBsAg loss or seroconversion was observed in 2.7-5% of patients taking tenofovir for between 11 and 17 months.<sup>99</sup> In a small study with lamivudine resistant patients, HBsAg loss occurred in 14% after a mean duration of 44 weeks.<sup>124</sup>

HBeAg seroconversion occurred in 21% at week 48 and 26% at week 64 (**Table 7**).<sup>85, 125</sup> HBeAg loss occurred in 35% of lamivudine-resistant patients treated with tenofovir and followed for 72 to 130 weeks.<sup>124</sup>

Treatment with tenofovir results in a 4-6 log IU/ml decline in HBV DNA within 48 weeks when given at a dose ranging from 300mg once daily.<sup>99, 124</sup> A randomised trial demonstrated a greater proportion of patients with undetectable HBV DNA after 48 weeks of treatment with tenofovir compared to adefovir (69% vs. 9%, respectively).<sup>99</sup> In an open label extension, the percentage of tenofovir treated patients with undetectable HBV DNA increased to 89% by week 76.<sup>99</sup> No subject developed mutations associated with tenofovir resistance by week 48 and no patient had a loss of viral response between week 48 and week 72.<sup>99, 124</sup>

Tenofovir has also been successfully used for the treatment of patients who failed consecutive therapy with lamivudine and lamivudine/ adefovir combination.<sup>126</sup>

## 8 TREATMENT HBeAg-NEGATIVE CHB

### First Line Treatment Options

Treatment with a nucleoside/nucleotide analogue or pegylated interferon is appropriate. Patient age, severity of liver disease and tolerance for adverse events are factors that may influence the agent used. A potent drug with a high genetic barrier should be chosen. Tenofovir and entecavir preferred first-line nucleoside / nucleotides for patients with HBeAg-negative disease. (I) Adefovir is also appropriate. Lamivudine and telbivudine are not recommended due to the risk of resistance. (I) The optimal duration of treatment is not defined and, in general, treatment should not be terminated unless there is seroconversion from HBsAg to anti-HBs.

Treatment with 48 weeks of pegIFN is also a preferred first-line option. (I) Longer treatment may be considered. (III) The efficacy of therapy is evaluated on the basis of suppression of HBV replication and ALT normalisation. **Figure 5** shows the treatment algorithm for HBeAg-negative CHB.

### Categorisation by Serum ALT Levels

Therapy in patients with HBV DNA levels <2,000 IU/mL and persistently normal ALT levels should only be considered in patients with significant histological disease. (II-1)

Treatment should be considered in patients with HBV DNA levels between 2,000-20,000 IU/mL and minimally elevated ALT levels (1-2 x ULN) if there is moderate/severe inflammation or significant fibrosis on biopsy. (I)

If ALT levels are elevated  $\geq 2$  x ULN and HBV DNA <2,000 IU/mL, evaluate for alternative causes of ALT elevation. Consider treatment in the absence of another cause and moderate/severe inflammation or fibrosis on biopsy. (I)

In patients with active viral replication, the severity and stage of liver disease is usually more advanced. All patients with serum HBV DNA >2,000 IU/mL and ALT levels >2 x ULN should be considered for liver biopsy and treatment. (I)

**Figure 5: Algorithm for HBeAg-negative Disease**

#### Treatment Considerations:

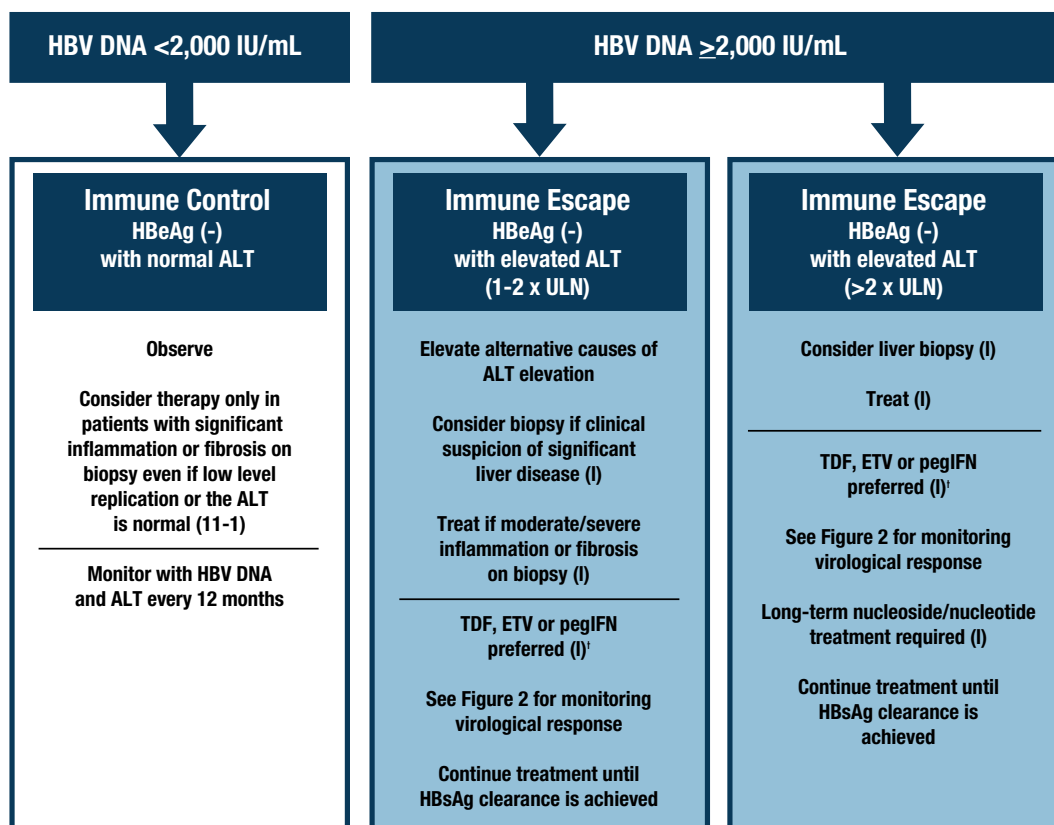

†Please refer to PBS / Pharmac Schedule for reimbursed indication

ADV adefovir  
ETV entecavir  
FTC emtricitabine

HBIG hepatitis B  
Immunoglobulin  
IFN standard interferon

LAM lamivudine  
LdT telbivudine  
NA nucleosides/ nucleotides

pegIFN pegylated interferon  
TDF tenofovir

## Antiviral Agents in HBeAg-negative CHB

### pegIFN

A large clinical trial of pegIFN-2a in HBeAg-negative patients reported a 2% HBsAg seroconversion rate among patients receiving pegIFN either as monotherapy or in combination with lamivudine.<sup>66</sup> Post-treatment virologic response rates were significantly higher in patients receiving pegIFN and dual therapy compared to lamivudine monotherapy.<sup>66</sup> In a similar study of pegIFN-2b, with or without lamivudine, virological response rates were similar in the pegIFN-2b monotherapy and dual therapy groups.<sup>127</sup>

Histologic improvement is more pronounced in patients with virological response.

Pre-treatment predictors of response include baseline ALT and HBV DNA, age and gender.<sup>128</sup>

### Lamivudine

The optimal duration of lamivudine therapy in HBeAg-negative patients is unknown.<sup>73, 129, 130</sup> Only 30–40% of lamivudine-treated HBeAg-negative patients maintain virological remission with continuous treatment due to the selection of lamivudine-resistant mutants.<sup>131–136</sup> One study suggested lamivudine could be stopped after two years in patients with persistently undetectable HBV DNA levels, with lower rates of relapse than reported in prior studies.<sup>136</sup> The rates of durable responses in another study increased significantly if undetectable HBV DNA occurred within 24 weeks of therapy.<sup>73, 110, 137</sup>

Approximately two-thirds of patients have a biochemical response after 6–12 months of lamivudine therapy,<sup>131, 138–140</sup> with necroinflammation improving in a similar proportion. In one study biochemical remission decreased from 84% at 12 months to 36% at 48 months, inversely proportional to the increase in lamivudine resistance.<sup>132</sup>

### Adefovir

Over a 240-week period of continuous adefovir monotherapy, 5% of patients experienced HBsAg loss and seroconverted to anti-HBs.<sup>72, 93</sup> Undetectable HBV DNA levels were reached in 71% after two years,<sup>72</sup> and complete viral suppression was achieved in 50–60% of patients at five years.<sup>93</sup> A decrease in HBV DNA levels to <200 IU/mL by treatment week 48 was highly predictive of maintenance of the response at year three with a low probability of HBV resistance.<sup>141</sup>

After 240 weeks, the cumulative probability of adefovir related polymerase mutations was 29%; virologic resistance was 20% and clinical resistance was 11%.

In a retrospective study of lamivudine resistant patients, undetectable HBV DNA was achieved by 76% in patients switched to adefovir monotherapy vs. 83% of patients treated with a combination of adefovir/lamivudine.<sup>142</sup> Rates of resistance were 18% with adefovir monotherapy and 3% with combination therapy.

Significant improvements in liver histology were observed following long-term treatment with adefovir.

After 192 or 240 weeks of treatment, over 83% of patients had improvement in necroinflammation, and over 73% had improvement in fibrosis. Ishak fibrosis scores improved compared with baseline in 35%, 55%, and 71% of patients after 48, 192, and 240 weeks of adefovir, respectively.<sup>93</sup>

### Entecavir

In treatment-naïve patients, entecavir was found to be significantly more effective than lamivudine in suppression of HBV replication over a 48-week period.<sup>73</sup> Undetectable serum HBV DNA was reported in 90% and 78% of patients treated with entecavir and lamivudine, respectively. Continued therapy through 96 weeks showed a significant difference in cumulative virologic response among entecavir (94%) and lamivudine (77%) treated patients.<sup>143</sup> Entecavir has a favourable resistance profile.

### Telbivudine

Undetectable levels of HBV DNA were reported in 79% of HBeAg-negative patients after a two year treatment period.<sup>95</sup> Resistant strains, which were cross resistant to lamivudine, emerged after one year in 2% of patients and after two years in 9% of patients.

### Tenofovir

Preliminary findings from a randomised trial demonstrated a greater proportion of patients (both lamivudine experienced and naïve) achieved undetectable HBV DNA with tenofovir compared to adefovir (91% vs. 51%, respectively) after 48 weeks treatment.<sup>144</sup> This increased to 98% in the tenofovir group at 72 weeks and in patients switched from adefovir to tenofovir at 48 to 72 weeks.<sup>98</sup> Both adefovir and tenofovir showed a similar profile with approximately 77% of patients achieving normalisation of ALT by 48 weeks.<sup>144</sup> No resistance was identified through 72 weeks of therapy.<sup>98</sup>

## 9 MANAGING ANTIVIRAL RESISTANCE

### Clinical Consequences of Resistance

Antiviral resistance is now the single most important factor in the failure of nucleoside/nucleotide analogue treatment regimens. Antiviral resistance limits the efficacy of therapy. Patients with antiviral resistance mutations experience greater rates of disease progression than treated patients without such mutations (Figure 6).<sup>103</sup> The development of clinical resistance has been linked with hepatitis flares and an increased risk of hepatic decompensation and death from liver failure.<sup>103,104</sup> Some patients may show rapid deterioration with acute exacerbation of the disease, especially in patients with cirrhosis and with pre-core mutant infection.<sup>131,145</sup> In other cases, deteriorating liver disease starts progressively after the development of viral drug resistance.

### Dynamics and Definitions of Resistance

Indications of emergence of antiviral drug resistance include (Figure 7):<sup>103,104,146</sup>

#### Genotypic Resistance

Mutation(s) in the HBV genome develop specifically during antiviral therapy and confer resistance to the antiviral agent.<sup>147</sup> Two types of mutations are observed:

- Primary resistance associated mutations (lamivudine: rtM204V/I and rtN236T)
- Secondary / compensatory mutations (lamivudine: rtL80V/I and rtL180M)

#### Virological Breakthrough

Rebound in serum HBV DNA ( $\geq 1 \log_{10}$  IU/mL from the nadir), in two consecutive serum samples taken one month apart in patients who have responded to therapy, following the development of genotypic resistance.<sup>147</sup>

#### Clinical Breakthrough

Virological breakthrough may be followed by an increase in ALT levels and subsequent progression of liver disease.<sup>103,104</sup>

Ideally, therapeutic intervention should occur before clinical breakthrough to maximise treatment outcomes.

Figure 6: Resistance is Associated with Greater Progression of Liver Disease<sup>103</sup>

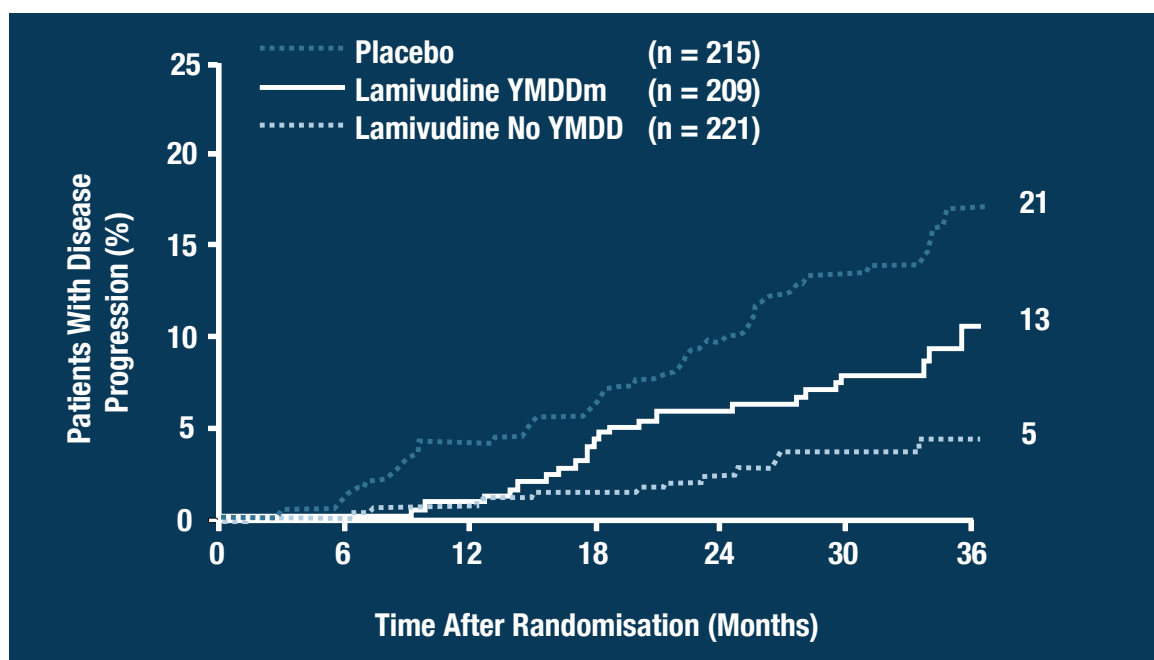
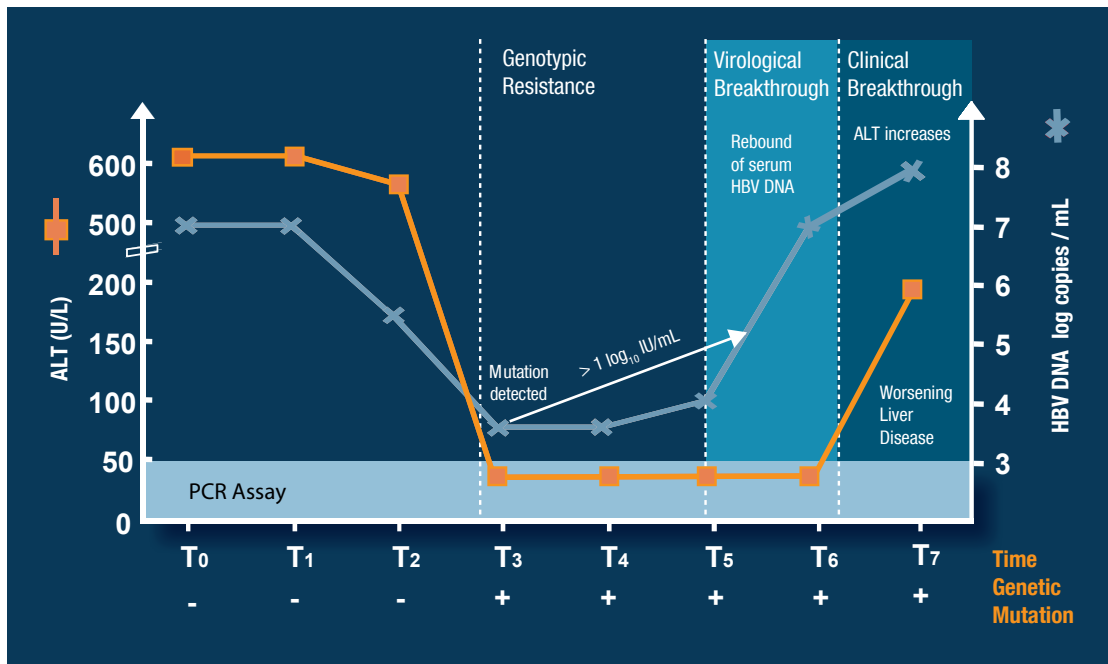

Figure 7: Dynamics of Antiviral Resistance in CHB<sup>148</sup>



## Pathways and Patterns of Resistance Mutations

The chemical classification of these agents impacts the patterns and pathways of drug resistance. Distinct chemical groups can be recognised:

### 1. Nucleoside Group

- pyrimidine base - lamivudine, telbivudine
- purine base - entecavir

### 2. Nucleotide Group

- acyclic phosphonate - adefovir, tenofovir

Primary drug resistance mutations refer to amino acid change(s) that result in reduced susceptibility to an antiviral agent. Secondary compensatory mutations restore replication defects associated with primary drug resistance and may be associated with low level reduced susceptibility.<sup>146</sup>

The primary resistance mutations associated with drug failure are shown in **Figure 8**.

Eight codons in the HBV polymerase are associated with primary drug resistance. They fall into five major pathways based on the chemical classification of each nucleoside / nucleotide.<sup>146</sup>

- The rtM204V/I pathway is responsible for resistance to the L-nucleosides, such as lamivudine, telbivudine, and entecavir in lamivudine resistant patients
- The rtN236T pathway is responsible for adefovir and tenofovir resistance
- A shared pathway (rtA181T/V), is associated with resistance to lamivudine and adefovir and is a potential multi-drug resistance pathway.
- In naïve patients treated with entecavir, at least three mutations arising at the same time are required: rtL180M + rtM204V plus either one of rtT184, rtS202 or rtM250 codon changes.
- Multidrug resistance pathways. In highly drug-experienced patients, clusters of mutations such as rtA181T/I233V/N236T/M250L, all on the one dominant HBV genome, are being detected in association with multi-drug resistance.

Figure 8: The Important Eight Codons Associated with Primary Resistance<sup>149</sup>

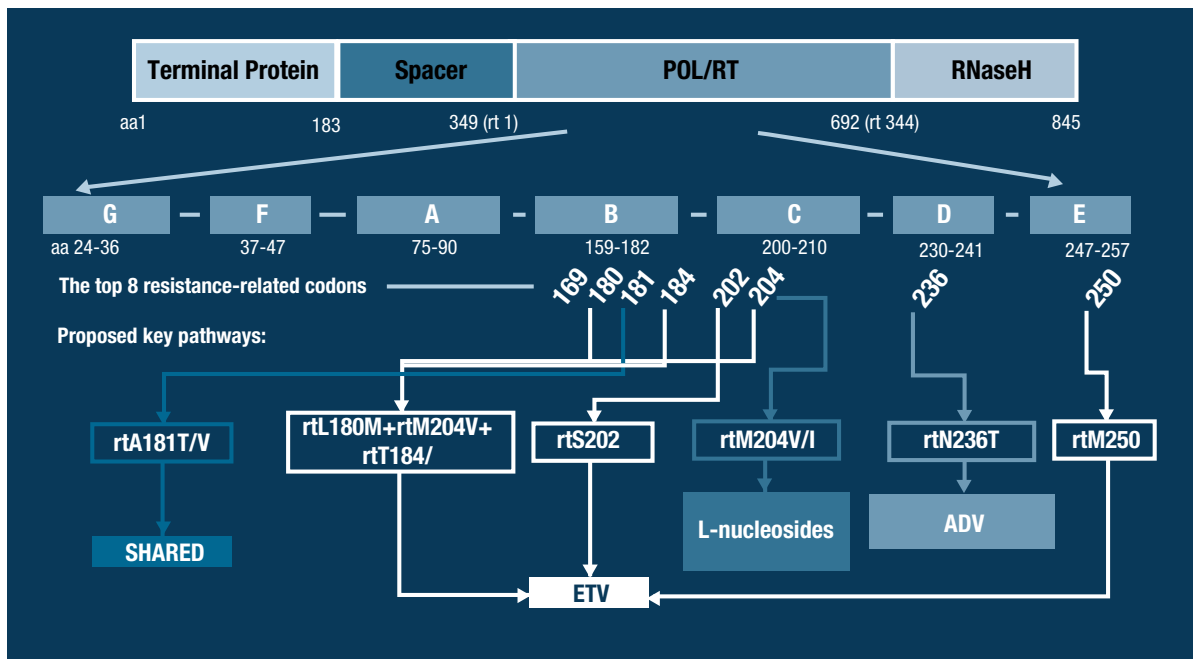

ADV, adefovir; ETV, entecavir; LAM, lamivudine; LdT, telbivudine; TDF, tenofovir mapped onto the HBV polymerase gene

## Cross Resistance

Cross-resistance occurs when there is a decreased susceptibility to more than one antiviral drug conferred by the same amino acid substitution or combination of amino acid substitutions. Results of in vitro cross-resistance data are summarised in Figure 9.<sup>150</sup>

In general, drugs within the same structural family are more likely to exhibit cross-resistance. For instance, lamivudine-resistant mutants (rtM204V or rtM204I mutants) are resistant to other nucleoside pyrimidine analogues such as telbivudine while they remain susceptible to nucleotide analogues such as adefovir and tenofovir.<sup>151-154</sup>

Current data suggest that the development of entecavir resistance follows a “two hits” model with the first selection of primary resistance mutations at position rt204, followed by the addition of secondary resistance mutations (at position rt184, rt202, or rt250) conferring higher resistance to entecavir.<sup>155, 156</sup> This may be why the development of entecavir resistance is more rapid in patients with lamivudine failure who already have selected the primary resistance mutations, by comparison with the nucleoside naïve patients in whom the whole process of selection of primary and secondary mutations needs to take place.

The adefovir-resistant mutant (rtN236T) is susceptible to the nucleosides - lamivudine, telbivudine and entecavir, while the rtA181V mutant has a reduced susceptibility to lamivudine.<sup>118, 126, 157</sup>

Uniquely, tenofovir can be used in both naïve patients and those with first-line treatment failure as it is active against lamivudine, entecavir, telbivudine and even adefovir resistant mutants.<sup>158</sup>

**Figure 9: Cross Resistance Profiles of Nucleosides and Nucleotides<sup>150</sup>**

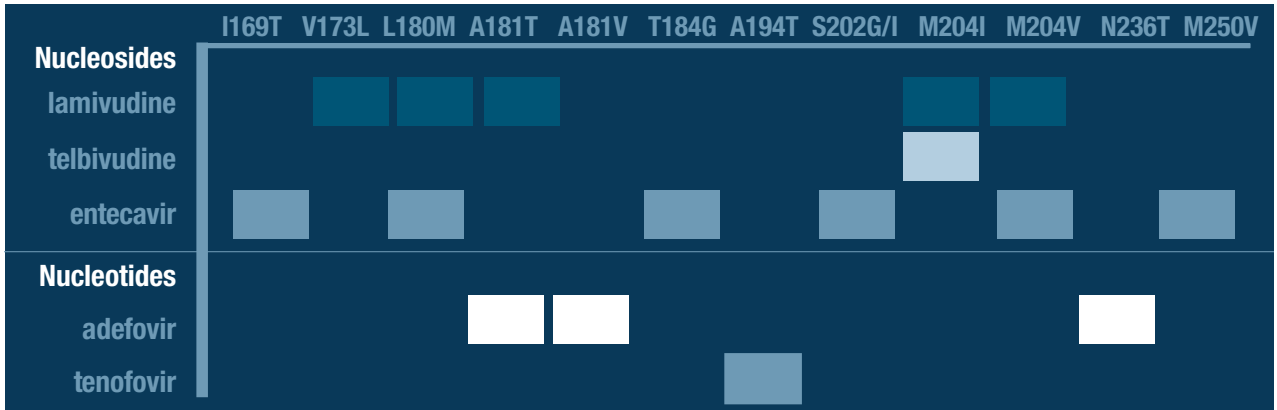

Tenofovir A194T mutation has been reported in two HIV/HBV co-infected patients following combination therapy with tenofovir and lamivudine. The clinical significance of this mutation is unknown.

### Multi-drug Resistance

Sequential treatment with antiviral monotherapy has resulted in the selection of mutations conferring resistance to both the initial therapy and the rescue therapy leading to multi-drug resistance.<sup>159,160</sup>

For example, sequential resistance to lamivudine and later adefovir or entecavir has been reported in patients who were switched to another agent after lamivudine-resistance developed.<sup>156, 160-162</sup>

Additional data indicate combination therapy may not be effective in suppressing multi-drug resistance once it emerges.<sup>118, 126</sup>

The use of an add-on strategy with drugs from the same structural family and similar cross-resistance profiles (i.e. nucleoside + nucleoside) may lead to the selection of multi-drug resistant strains if the add-on strategy does not induce complete viral suppression, especially if there is a large replication space available for the mutants to spread.<sup>126</sup>

### Rates of Resistance

Comparative rates for the development of resistance to various agents are given in **Table 8**. The rate at which resistant mutants are selected is related to pretreatment serum HBV DNA level, the number of mutations required to produce resistance (genetic barrier), the potency and

rapidity of viral suppression, duration of treatment, and prior exposure to antiviral therapies.<sup>163</sup>

The incidence of genotypic resistance also varies with the sensitivity of the methods used for detection of resistant mutations and the patient population being tested.

### Nucleosides

Lamivudine resistance rates are high and can be detected in 14-32% after one year of treatment<sup>68, 111, 131, 164</sup> increasing with the duration of treatment to around 60-70% at 5 years of treatment.<sup>108, 109</sup> Although telbivudine is associated with lower resistance rates, resistance increases significantly after the first year of treatment.<sup>90</sup> In contrast, entecavir has a higher genetic barrier and virologic breakthrough is rare in nucleoside-naïve patients, but high in lamivudine resistant patients (up to 51% at year 4).<sup>120, 122, 165</sup>

### Nucleotides

In naïve patients, adefovir resistance occurs at a slower rate compared with lamivudine. In lamivudine-refractory patients the resistance rate is significantly higher.<sup>72, 166-168</sup> Accumulating evidence suggests tenofovir has a very high genetic barrier to resistance. Studies show a low rate of resistance in naïve as well as nucleoside / nucleotide experienced patients. In phase III trials, no patients developed mutations associated with resistance at 72 weeks.<sup>98, 125</sup>

**Table 8: Cumulative Rates of Antiviral-Resistance Reported in Clinical Trials (%)**

Treatment		Rates of genotypic resistance (%)				
		Yr1	Yr2	Yr3	Yr4	Yr5
<b>Nucleosides</b>	Lamivudine <sup>82, 108, 109</sup>	24	38	49	67	70
	Telbivudine <sup>95, 123</sup>	3-4	8-21			
	Entecavir (treatment naïve patients) <sup>122</sup>	0	0.5	1.2	1.2	1.2
	Entecavir (lamivudine resistant patients) <sup>122</sup>	6	15	36	46	51
<b>Nucleotides</b>	Adefovir (treatment naïve patients) <sup>93</sup>	0	3	11	18	29
	Adefovir (lamivudine resistant patients) <sup>94, 168</sup>	5	20	16		
	Adefovir + lamivudine combination (lamivudine resistant patients) <sup>169</sup>	0	0	0	0	
	Tenofovir (Naïve and lamivudine resistant patients) <sup>99</sup>	0	0			

## Resistance Prevention Strategies

A reasonable clinical goal is to develop an overall strategy that prevents the selection of resistance.

Prevention of resistance requires the adoption of strategies that effectively control virus replication (Table 9).<sup>170</sup>

## Monitoring Virologic Response and Breakthrough

It is important to detect resistance early before the viral load rebounds fully and before ALT levels rise.<sup>150, 171</sup> Treatment is more likely to be effective if a new agent is introduced when the viral load is low than when it is high. To ensure viral load is detected early, HBV DNA concentration should be measured at 12 weeks and then every three to six months (see: **6 Monitoring On and Off-Treatment Response**). (II-2) Virological testing should be performed to confirm that viral breakthrough is due to resistance rather than poor adherence. (II-2) Treatment should be modified as soon as resistance is identified.

**Table 9: Resistance Prevention Strategies**

<b>Maximise antiviral activity</b>	Select most potent regimen, with the highest genetic barrier, to suppress viral replication as quickly and completely as possible
<b>Maximise genetic barriers to resistance</b>	Avoid sequential monotherapy <sup>160</sup> Avoid treatment interruptions Choose drugs requiring multiple resistance mutations <sup>147</sup> (single therapy or a combination of drugs with different resistant profiles)
<b>Increase pharmacologic barriers to resistance</b>	Ensure patient compliance Modify treatment strategy early before viral load rebounds

## 10 COMBINATION AND DUAL THERAPY STRATEGIES

### Combination Therapy

Combination therapy, defined as treatment with two or more nucleoside / nucleotide agents, theoretically conveys two advantages:<sup>137, 171</sup>

The most potent agent may provide an 'additive' effect and produce a greater suppression of viral replication than the weaker single agent.

The risk of treatment-emergent resistance may be reduced by targeting multiple sites in the replication pathway, thus requiring multiple mutations to occur to produce antiviral resistance.

#### Target Patients

Combination therapy is for patients who have the highest risk of resistance (for example, long standing infection and high viraemia levels associated with more complex viral populations prior to therapy, together with high ALT levels).<sup>82</sup>

An equally important group for preferred use of combination therapy exists in those patients who can least afford to develop antiviral drug resistance from a clinical perspective (for example, patients with liver cirrhosis and/or with HBV recurrence after liver transplantation).

Because of the risk of development of multi-drug resistance, the choice of first-line treatment should be made with caution. It is also likely that development of multi-drug resistance could be reduced by complementary combination therapy optimised to individual viral phenotypes, although this strategy requires confirmation of efficacy, safety and cost-effectiveness in clinical trials.<sup>146</sup> The choice of drug for adding should be based on the absence of cross resistance.

#### Early Add-On

Cross-resistance data and the results of long-term studies advocate for an add-on therapy at an early stage, i.e., viral breakthrough, to control rapidly viral replication and prevent clinical deterioration.

The early add-on strategy begins with a potent drug with a high genetic barrier. A second drug is added if there is an sub-optimal response to treatment after 24-48 weeks (see: **6 Monitoring On and Off-Treatment Response**).<sup>150</sup> Initiating rescue therapy early is more effective, and maximises.

treatment outcomes, compared to delaying rescue therapy until viral rebound or biochemical breakthrough occurs.<sup>137</sup>

Figure 10: Early Add-on Treatment Approach<sup>89</sup>

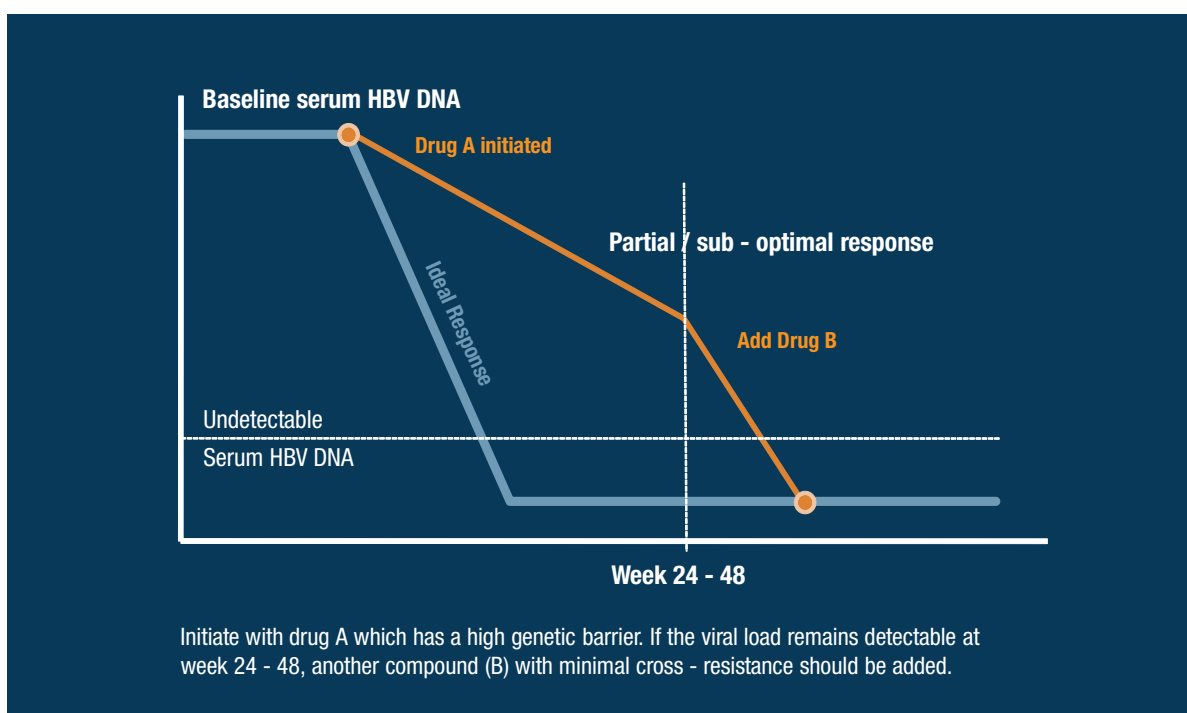

## Avoid Cross Resistance

When evaluating combination treatments consequences of cross-resistance need to be carefully considered.<sup>171</sup> Combining two antiviral agents which are not cross-resistant (for example, a nucleotide and a nucleoside) may delay or prevent the occurrence of viral resistance without compromising tolerance (**Figure 9**). The nucleotides (adefovir and tenofovir) show consistent activity against the wild-type and all patterns of lamivudine resistant strains. HBV isolates with entecavir-associated mutations are also sensitive to adefovir and tenofovir according to **in vitro** and **in vivo** data.<sup>156</sup>

**Table 10: Summary of Resistance Management Strategies to Specific Antivirals**

<b>Lamivudine Resistance</b>	Add adefovir or Switch or add tenofovir
<b>Adefovir Resistance*</b>	Add lamivudine, telbivudine or entecavir or Switch to tenofovir or tenofovir plus nucleoside agent or Switch to entecavir (if no prior lamivudine resistance)
<b>Entecavir Resistance*</b>	Add adefovir or tenofovir Switch to tenofovir
<b>Multidrug Resistance#</b>	The optimal rescue therapy is not known but one option is to add tenofovir (if the patient is not on adefovir) in combination with a nucleoside analogue  The most effective treatment of multidrug-resistant CHB is prevention through judicious use of antiviral therapy and avoidance of sequential antiviral monotherapies.

\* Limited in vivo data, available data indicate that addition of rescue therapy is less likely to result in sequential drug resistance than switching to rescue therapy.

# In vivo data lacking.

## Combinations for Lamivudine Resistance / Non-Response

Recent studies show adefovir added after viral breakthrough, but before clinical breakthrough is the preferred treatment for lamivudine resistant patients. **(I)**<sup>137</sup> Under these circumstances, control of viral replication is effective and the rates of adefovir resistance are low.<sup>115, 167, 169, 172-174</sup> Switching to adefovir alone is associated with higher rates of adefovir resistance and is not recommended (**Table 8**). **(I)**<sup>94, 175</sup>

Tenofovir is effective in suppressing lamivudine-resistant hepatitis B, but whether tenofovir should be added or simply substituted for lamivudine has not been addressed.<sup>161</sup>

Entecavir is not a good agent for lamivudine resistant patients because the response to entecavir is blunted.<sup>176</sup> For entecavir, lamivudine resistance mutations are considered as primary entecavir resistance mutations and resistance rates can occur in 36% after three years.<sup>89, 121, 154, 161, 176, 177</sup>

Telbivudine is not effective because virus that is resistant to lamivudine has a high likelihood of being resistant to telbivudine.

## Combinations for Adefovir Resistance / Non-Response

Genotypic resistance to adefovir monotherapy occurs in approximately 29% of patients after five years.<sup>93</sup> Clinical breakthrough occurs in approximately 11%.<sup>93</sup> Lamivudine, telbivudine or entecavir may all potentially be used in combination with adefovir,<sup>118, 157, 178</sup> although there are no large scale trials confirming efficacy of these agents in adefovir resistant patients.

## Combinations for Lamivudine / Adefovir Resistance / Non-Response

Evidence suggests that viral suppression can be obtained with tenofovir.<sup>157, 162, 179, 180</sup> Whether tenofovir should be used as monotherapy or in combination with a nucleoside analogue has not been established.

## Combinations for Entecavir Resistance / Non-Response

In vitro data suggest that adefovir and tenofovir could be used in combination with entecavir,<sup>155, 162</sup> however these findings await confirmation in clinical trials.

### Combinations for Telbivudine Resistance / Non-Response

Little is known about treatment of telbivudine resistance, which occurs in around 21% of patients at the end of two years of therapy.<sup>90</sup> Cross-resistance with lamivudine and emtricitabine can be expected. There is some support for the investigation of telbivudine as a component in a multi-drug strategy, especially with nucleotide analogues. It is not recommended in combination with entecavir due to the cross-resistant profiles.

### Combinations for Tenofovir Resistance / Non-Response

Clinical resistance to tenofovir has not been described in CHB patients. The true resistance rate is not known.

## Dual Therapy (Nucleoside /nucleotide analogue + pegIFN)

There are theoretical advantages for dual therapy with an immunomodulator (IFN/pegIFN) added to a nucleoside/nucleotide analogue. Synergistic activity is potentially created by targeting dual pathways. pegIFN may enhance immune clearance of infected hepatocytes while the antiviral stops viral replication. To date, clinical outcomes of dual therapy trials have only been conducted over a 48 week period and outcomes have not shown an advantage of combination therapy over pegylated interferon alone.

### Dual Therapy with pegIFN and Lamivudine

The combination of pegIFN and lamivudine has been assessed in three large, multicentre trials with both HBeAg-positive and HBeAg-negative patients.<sup>65-67</sup> The degree of viral load suppression at the end of treatment was higher in those on a lamivudine-containing regimen than those on pegIFN-2a alone (7.2 log vs. 4.5 log respectively in the HBeAg positive study and 5.0 log vs. 4.1 log respectively in the HBeAg negative study), but the rate of sustained disease remission 24 weeks after treatment was higher in the pegIFN-2a monotherapy arm.<sup>65, 66</sup> This finding suggests that the mechanism of viral load reduction, in addition to the degree of viral suppression, is an important factor affecting sustained disease remission.<sup>66</sup>

### Dual Therapy with pegIFN and Adefovir

A small pilot study of 26 patients, dual therapy with adefovir and pegIFN-2b over 48 weeks lead to a higher rate of HBeAg seroconversion (53%) when compared to historical cohorts, and a higher rate of HBsAg seroconversion (15%).<sup>181</sup> Serum HBV DNA was undetectable in 54% of patients. Marked decreases in intrahepatic cccDNA occurred. Whether this combination is more effective than pegIFN alone awaits further study.

## 11 TREATMENT OF PATIENTS WITH CIRRHOSIS

**In HBeAg-positive CHB, the incidence of cirrhosis is estimated to be 1.6 to 3.8 per 100 person-years.<sup>182</sup> and 2.8 to 9.7 per 100 person-years in HBeAg-negative CHB.<sup>183</sup> Approximately 15% of patients with compensated cirrhosis will decompensate over 5 years.<sup>182</sup> Patients with compensated CHB-cirrhosis have a liver related mortality rate between 2.9 and 3.3 per 100 person years.<sup>182</sup> Mortality rates rise significantly once hepatic decompensation occurs.**

### Goals of Therapy

In patients with HBV-related cirrhosis, the principal goal of treatment is to prevent the development of hepatic decompensation and hepatocellular carcinoma.<sup>184</sup> Therefore treatment aims are:

1. Control of viral replication with undetectable HBV DNA
2. Control of hepatic inflammation with normal serum ALT levels

### Risk Factors

Risk factors associated with an increased risk of progression to cirrhosis or hepatic decompensation, include active viral replication, older age, male gender, advanced fibrosis on biopsy, concomitant alcohol use and co-infection with other hepatitis viruses (C or D) or HIV.<sup>185-187</sup>

### Patients to Treat

#### Patients with Compensated Cirrhosis

Independent of HBeAg status, treatment should be considered for patients with elevated ALT and for patients with normal or minimally elevated ALT, if serum HBV DNA levels are >2,000 IU/mL. **(II-2)** If the HBV DNA is lower than this threshold, patients should be observed closely with measurements of HBV DNA and ALT every three months and considered for therapy if these measurements remain persistently high.

#### Patients with Decompensated Cirrhosis

All patients with hepatic decompensation should be treated with an antiviral agent regardless of HBV DNA concentration to suppress viral replication and prevent possible flares in disease activity. Such patients should be considered

for liver transplantation and selection of the appropriate HBV therapy should be made in consultation with the local liver transplant program.

Treatment should be promptly initiated with a nucleoside / nucleotide analogue that can produce rapid viral suppression with low risk of drug resistance. **(II-1)**

**Figure 9** shows the treatment algorithm for patients with compensated and decompensated cirrhosis.

## Treatment Considerations

### Compensated Cirrhosis

Patients with compensated cirrhosis are best treated with nucleosides / nucleotides analogues. Clinical studies indicate that fibrosis and cirrhosis progression can be stabilised or even reversed if viral suppression can be maintained.<sup>180, 188, 189</sup>

These agents can also reduce the risk of hepatic decompensation and possibly the development of HCC.<sup>103,188</sup> In view of the need for long-term therapy, either tenofovir, entecavir or adefovir is preferred. **(II-3)**

Long-term treatment is recommended and thus surveillance for emergence of resistance and encouragement for the patient to be compliant with treatment are critical. However, treatment may be stopped in HBeAg-positive patients with confirmed HBeAg seroconversion and who have completed at least 6 months of consolidation therapy and in HBeAg-negative patients if they have confirmed HBsAg clearance. **(II-3)** PegIFN may be used with caution in early, well compensated cirrhosis.<sup>64</sup> PegIFN should be immediately discontinued if ALT increases are severe and progressive despite reduction of pegIFN dosage or if there is an accompanying increase in bilirubin or evidence of hepatic decompensation. The safety and optimal dose of pegIFN in patients with compensated HBV-cirrhosis remains to be established in larger studies.

Close monitoring for viral relapse and hepatitis flare is mandatory if treatment is stopped. **(II-3)**

### Hepatic Decompensation

In patients with decompensated cirrhosis the development of antiviral resistance may be associated with a potentially fatal flare of disease activity.<sup>178</sup>

Select a potent first-line agent with a high genetic barrier. Add a second agent, without cross resistance, early to maximise treatment outcomes if there is inadequate viral suppression with the single agent (see: **10 Combination & Dual Therapy Strategies**).

Whilst lamivudine and adefovir have been shown to stabilise or improve hepatic function, diminish the need for liver transplantation and reduce CHB recurrence following liver transplantation,<sup>190-193</sup> it is preferable to use combinations with a higher genetic barrier. Tenofovir and entecavir have

not been fully evaluated for use in this patient population, but, barring unexpected toxicity, should be effective agents. The combination of tenofovir / lamivudine may be a promising rescue therapy for these patients, particularly those with pre-existing resistance.<sup>180</sup> Renal function must be monitored carefully if adefovir and tenofovir are used. Life-long treatment is recommended. **(II-3)**

PegIFN is contraindicated in patients with decompensated liver disease.<sup>194</sup>

**Figure 11: Algorithm for Compensated and Decompensated Cirrhosis**

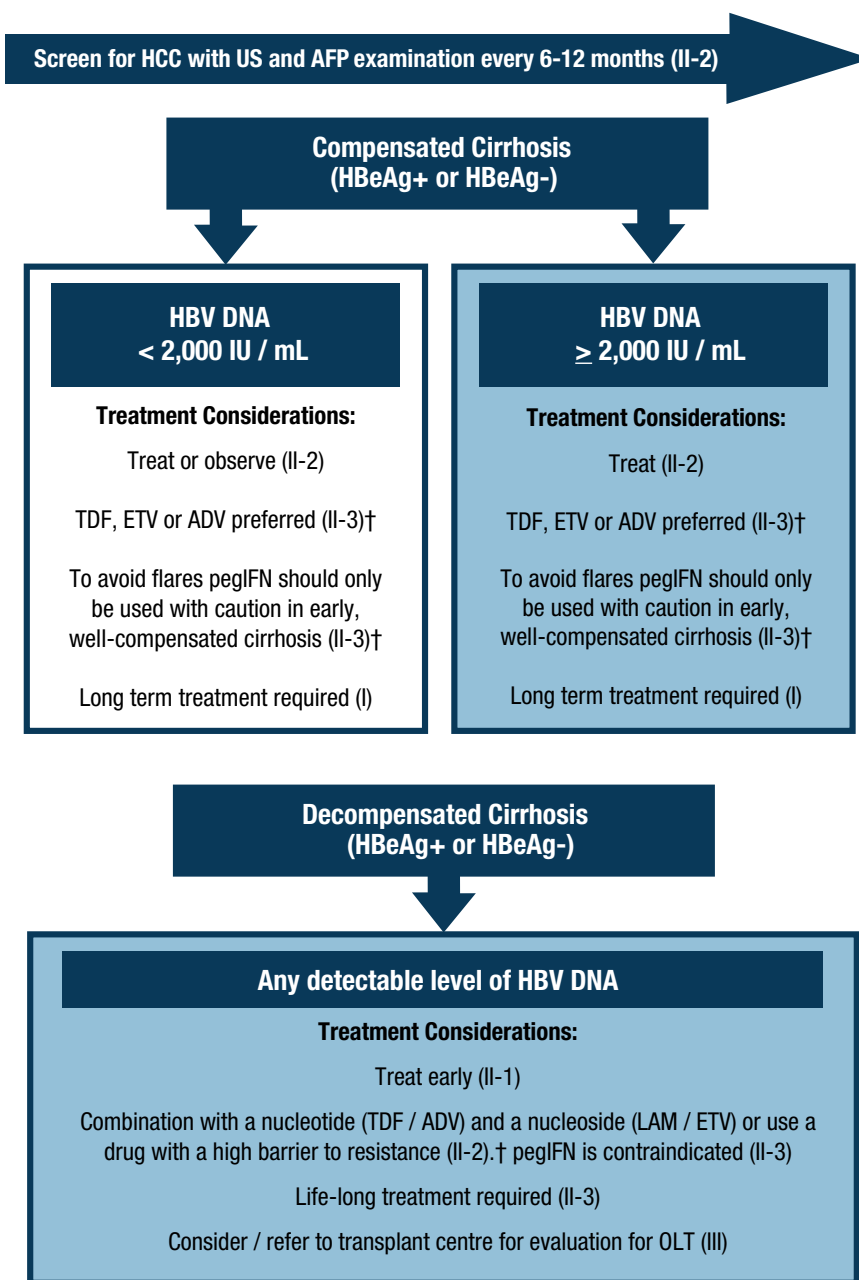

†Please refer to PBS / Pharmac Schedule for reimbursed indication

ADV adefovir  
ETV entecavir  
FTC emtricitabine

HBIG hepatitis B Immunoglobulin  
IFN standard interferon  
LAM lamivudine

LdT telbivudine  
pegIFN pegylated interferon  
TDF tenofovir

## 12 SPECIAL POPULATIONS

### HIV/HBV Co-infection

HIV/HBV co-infection has become a significant global health problem. The prevalence of HBV co-infection in HIV-infected patients is approximately 10%.<sup>195</sup> CHB prevalence is higher among HIV-infected persons than among the general population.

Liver disease is one of the leading causes of morbidity and mortality in individuals with HIV infection,<sup>196</sup> particularly those co-infected with HBV.<sup>197</sup> Co-infected patients are less likely to clear acute HBV infection spontaneously, tend to have higher HBV replication and more histologically advanced disease compared to mono-infection with either virus.<sup>197-199</sup> Optimal management of CHB is a priority in HIV/HBV co-infected patients.

#### Goal of Therapy

The principal goal of treatment in co-infection is the same as in mono-infection, to prevent or delay the development of cirrhosis and hepatocellular carcinoma.<sup>184</sup> To achieve this, treatment objectives are:

1. Undetectable HBV DNA by PCR
2. ALT within normal limits

#### When to Treat

Treatment of co-infected individuals is complex, and there are a number of unresolved management issues<sup>196, 200</sup> including the role of liver biopsy, the significance of normal ALT levels, HBV DNA treatment thresholds, treatment endpoints, and the treatment of HBV when HIV does not yet require treatment.

Treatment of HBV should be considered in individuals with HIV/HBV coinfection with evidence of significant fibrosis ( $\geq F2$ ), or with elevated serum HBV DNA levels ( $>2,000$  IU/mL).

**(III)**<sup>196, 201</sup> Patients who do not meet criteria for anti-HIV treatment should undergo a liver biopsy to evaluate hepatic inflammation and fibrosis stage. **(II-3)** Those with a METAVIR fibrosis score  $\geq F2$  should receive antiviral therapy for CHB.<sup>201</sup>

#### Treatment Considerations

At present, treatment of HBV in HIV/HBV co-infection is lifelong. If antiretroviral therapy is required, then two agents with anti-HBV activity should be incorporated into the regimen.

Close monitoring is necessary to detect treatment failure or hepatic flares, such as immune reconstitution disease.

**Co-infected patients who do not meet criteria for anti-HIV treatment.** If highly active antiretroviral therapy (HAART) is not required in HBeAg-positive patients, consider pegIFN or adefovir.<sup>184</sup> Typically, pegIFN is not preferred for treatment of HBeAg-negative patients because the probability of achieving HBsAg seroconversion and maintaining HBV DNA suppression off-therapy is low. **(II-3)**<sup>201, 202</sup> These patients should not receive agents with dual activity (e.g. lamivudine, entecavir, tenofovir, and emtricitabine) which would increase the risk of early HIV resistance and may limit future HIV therapeutic options. **(III)**<sup>203-205</sup> Although telbivudine does not target HIV, telbivudine should not be used. **(II-3)** Patients generally need long-term maintenance therapy.

**Co-infected patients who meet criteria for anti-HIV and CHB treatment.** The immune restoration associated with HAART can improve control of HBV replication and induce loss of HBeAg in some patients,<sup>31</sup> but can also lead to increased immune-mediated liver injury.<sup>197</sup> On balance, use of HAART before severe immunosuppression develops may be beneficial. Still, potential interactions of therapy for CHB and HIV, including drug interactions, must be evaluated for each individual.

HAART that includes two dual-acting drugs (e.g. lamivudine, tenofovir, emtricitabine, entecavir) constitutes the preferred option for these patients.<sup>201, 206</sup> The best choice is to combine a nucleoside and a nucleotide analogue to prevent long-term resistance (i.e., tenofovir / lamivudine).

**(II-3)**<sup>206-210</sup> Adefovir can be substituted for tenofovir if the latter is contraindicated or otherwise not a desirable option.<sup>211</sup> Similarly, entecavir offers an alternative to emtricitabine or lamivudine.<sup>119, 184</sup>

If HAART is altered because of intolerance or lack of efficacy, the CHB component should be continued, or substituted with another agent.<sup>200</sup> Stopping CHB therapy has been associated with HBV reactivation and ALT flares.<sup>212</sup> If the patient has achieved HBeAg seroconversion an adequate course of consolidation treatment must be undertaken prior to discontinuation of CHB treatment.

**Co-infected patients who meet criteria for HAART only.** Individuals with persistent controlled HBV replication may not need agents with dual activity. Monitor ALT and serum HBV DNA every three months.<sup>184</sup> If CHB treatment does not begin at the same time as antiretroviral treatment, delay its introduction until HIV replication is controlled or there is evidence of liver disease. Specifically, monitor HBV DNA for the anti-HBV treatment thresholds.

**Co-infected patients with LAM-Resistance.** Lamivudine resistance is reported to be higher in HBV/HIV co-infection.<sup>213</sup> Detectable HBV viraemia >200 IU/mL at 48 weeks is a risk factor for the development of CHB drug resistance.<sup>210</sup> These patients require a HAART regimen with maximum activity against both viruses.<sup>201</sup> Lamivudine should be maintained and adefovir or tenofovir should be added. **(III)**<sup>206, 207, 214-217</sup>

**Co-infected patients with cirrhosis.** Cirrhotic patients should receive combination CHB therapy (e.g., tenofovir plus emtricitabine or lamivudine included in the HAART regimen or adefovir plus entecavir or telbivudine if there is no indication for anti-HIV therapy). Patients with cirrhosis should be monitored closely during the first 12 to 24 weeks of therapy because of risk of ALT flare and immune reconstitution hepatitis. Serum HBV DNA should be assessed every 12 weeks, especially for patients with CD4 counts <200 /mm<sup>3</sup>.<sup>201</sup> Patients with liver decompensation should be treated with combination anti-HBV therapy and considered for liver transplantation.

## HBV/HCV Co-infection

HBV and hepatitis C virus (HCV) co-infection is common. Patients who are co-infected represent a unique group with diverse serologic profiles. In patients with CHB, estimates of the rates of HCV coinfection vary from 9 to 30%, depending on the geographic region.<sup>218</sup> These numbers may underestimate the true number of patients with both viral infections because no large-scale studies have been performed, and there is a well-described phenomenon of “serologically silent” occult HBV infection (i.e. patients with negative HBsAg but detectable serum HBV DNA) in patients with chronic hepatitis C (CHC).<sup>219</sup> Combined CHB and CHC leads to more severe liver disease, higher rates of cirrhosis with decompensation and an increased risk of hepatocellular carcinoma.<sup>220-225</sup>

Co-infected HBV/HCV patients represent a treatment challenge. Several studies have shown that the two infections interact with each other, affect immune responses and can reciprocally (and simultaneously) inhibit each other.<sup>220, 221, 226-233</sup> Either virus can play a dominant role and both viruses have the ability to induce seroconversion of the other. The chronology of infection has a role in determining the dominant virus, and HBV and HCV can alternate their dominance.<sup>218</sup> However, the overall dominant effect appears to be HCV suppression of HBV.<sup>233-235</sup> Furthermore, co-infected patients have lower levels of both HBV DNA and HCV RNA than corresponding monoinfected controls, indicating that concurrent suppression of both viruses by the other virus can also occur.<sup>233</sup>

### Goal of Therapy

The principal goal of anti-HBV treatment in co-infection is the same as mono-infection, i.e. prevent or delay the development of complications of cirrhosis and hepatocellular carcinoma. To achieve this, treatment objectives are:

1. Undetectable HBV DNA and HCV DNA by PCR
2. ALT within normal limits

### When to Treat

There is no currently established standard of care for patients who are co-infected with HBV and HCV, although assessment of the “dominant” virus is helpful in determining a treatment strategy.

Thorough serologic and virologic testing is required in dually infected patients prior to consideration of therapy. Caution must be taken with treatment of co-infected individuals, as exacerbations of liver disease after initiation of therapy have been described. This is likely due to loss of viral suppression from the successfully treated dominant virus. Patients are candidates for therapy if they meet the inclusion criteria for standard treatment guidelines for either HBV or HCV mono-infection.

### Treatment Considerations

Treatment should be individualised based on patient variables such as serologic and virologic profiles, prior exposure to antiviral treatment, and the presence of other parenterally transmitted viruses such as hepatitis D virus and HIV. In general, the same treatment criteria should be applied to patients who are HBV/HCV dually infected as are applied to mono-infected patients.

**Co-infected patients with HCV dominant disease.** PegIFN plus ribavirin treatment in standard doses for twelve months is an option.<sup>236-239</sup> An initial study adding lamivudine to interferon was effective in coinfecting patients with CHC and active HBV replication.<sup>240</sup> Future studies are needed to assess the effectiveness of pegIFN as well as triple therapy with an antiviral active against HBV, pegIFN and ribavirin in coinfecting patients.

**Co-infected patients with HBV dominant disease.** PegIFN, with or without adefovir or entecavir, is a reasonable initial option.

**Co-infected patients with decompensated cirrhosis.** Referral to a transplant centre is indicated for patients with decompensated cirrhosis or HCC in appropriate patients. A few studies have found lower survival rates of patients with CHB/CHC monoinfection compared with dually infected patients, suggesting a possible beneficial role of viral coinfection in the immunosuppressed post-transplant population.<sup>241, 242</sup>

**Triple infection with HCV/HBV/HDV.** Few treatment studies have been published. On empirical grounds, pegIFN is a reasonable treatment option despite the lack of data to support its use.<sup>243</sup>

**Triple infection with HCV/HBV/HIV.** Data on treatment of patients with triple infection is scant, so treatment algorithms are often extrapolated from results of trials of patients with either HBV/HIV or HCV/HIV co-infection. As no standard of care exists for these patients, individual care plans should be coordinated with an HIV specialist and hepatologist.<sup>244</sup>

## HBV/HDV Co-infection

Hepatitis delta virus (HDV) is an incomplete RNA virus that only infects patients with pre-existing HBV infection. Approximately 5% of the global HBsAg carriers are also co-infected with HDV, leading to a total of 10-15 million HDV carriers worldwide.<sup>245, 246</sup> High prevalence areas of HDV infection include Italy, some parts of Eastern Europe, the Amazon basin, Venezuela, Columbia, some Pacific Islands, Pakistan, and Western Asia.<sup>247-251</sup>

Acute HDV infection can occur concurrently with HBV infection (co-infection) or in a patient with

established HBV infection (superinfection). Around 70-90% of infected patients will progress to chronicity and follow a rapid progressive course to cirrhosis.<sup>252, 253</sup>

## Goal of Therapy

The principal goal of CHD treatment is to prevent or delay the development of complications of cirrhosis and hepatocellular carcinoma. To achieve this, treatment objectives are:

1. Undetectable HDV RNA by PCR
2. ALT within normal limits

## Treatment Considerations

CHD is difficult to treat but, as the risks of end-stage liver disease are higher, active therapeutic intervention for CHB and D is required.<sup>254-261</sup>

Many studies have investigated standard interferon treatment in CHD.<sup>261-264</sup> Recent studies show pegIFN treatment at standard doses for a minimum of 12 months is a promising option. **(II-2)** Persistent disappearance of HDV RNA after 6-12 months of treatment with pegIFN in previous standard interferon nonresponders has been reported.<sup>255, 265</sup> In small studies, a sustained response (categorised as undetectable HDV RNA by PCR and normalisation of ALT six months after treatment) was achieved in 17-43% of CHD patients.<sup>254, 266, 267</sup> Nonresponders were identified by a <3 log decrease of HDV RNA at 6 months of treatment.

In CHD patients, there is no evidence that ribavirin,<sup>256, 257</sup> acyclovir<sup>268</sup> or lamivudine,<sup>258, 269-272</sup> alone or in combination with interferon-based therapy, enhances treatment outcomes.

## Chemo- and Immunosuppressive Therapy

Patients with CHB have a substantial risk of reactivation and jaundice following the use of immunosuppressant therapy. While the majority of cases have been reported among patients who are HBsAg positive, any previous exposure to HBV infection increases the risk of reactivation.<sup>273</sup> The risk of reactivation for HBsAg-positive patients undergoing chemotherapy is between 33 and 67%<sup>273, 274</sup> and mortality rates, primarily related to liver failure, range from 4-60%.<sup>275</sup> Reactivation may also interrupt cancer treatment. Treatment delays for up to 100 days contribute to lower disease free and lower overall survival.

In a study of breast cancer patients, over 70% with HBV reactivation required premature termination of chemotherapy or disruption of treatment.<sup>276</sup>

Regimens containing high dose steroid or rituximab independently increase risk.<sup>277</sup> Patient factors conferring increased risk include high serum HBV DNA pre-chemotherapy, sex and high levels of ALT.<sup>278, 279</sup>

### Screening

HBsAg screening should be performed in all persons, prior to initiation of chemo- or immunosuppressive therapy. **(I)** All patients undergoing bone marrow or solid organ transplantation or immunosuppressive monoclonal antibody therapy (rituximab, infliximab) should be screened for HBV markers prior to treatment. **(I)**

### Treatment Considerations

**HBV naïve patients.** Patients should be immunised against hepatitis B, as should haematopoietic stem cell donors.

**HBsAg or HBV DNA positive patients. (III)**<sup>275, 280-283</sup>

Prophylactic lamivudine can prevent or at least ameliorate the course of reactivation. **(I)**<sup>277, 280, 284-286</sup> with a systematic review identifying a reduction in reactivation rates of between four and sevenfold.<sup>286</sup> Preemptive prophylactic lamivudine therapy also increases the likelihood of patients completing chemotherapy without interruption.<sup>280</sup>

The optimal duration of lamivudine prophylaxis remains controversial. People with high baseline HBV DNA >2,000 IU/mL should continue treatment until they reach treatment end points for CHB. **(III)** Those with baseline HBV DNA <2,000 IU/mL should continue treatment for at least six months to 1 year following the completion of chemotherapy.<sup>276, 280, 284, 287</sup>

Whilst lamivudine has the largest body of evidence in the setting, newer analogues such as adefovir, tenofovir and entecavir are likely to be equally effective particularly in patients who require more than 12 months of therapy. **(III)** In immunosuppressed patients, a cumulative resistance rate of 41% after 31 months in HBsAg-positive patients receiving lamivudine has been observed. In these cases, the administration of additional or alternative antiviral agents may be necessary. PegIFN/IFN should be avoided in view of the bone marrow suppressive effect and the risk of exacerbating immune-mediated diseases (autoimmune disorder, graft rejection, or graft vs. host disease). **(II-3)**

### HBsAg-negative, anti-HBc positive patients.

While HBsAg-negative patients are at lower risk of reactivation (<5%), re-emergence of HBV may be severe and even fatal. Currently there is insufficient information to recommend routine nucleoside/nucleotide analogue prophylaxis for these individuals. Patients should be monitored regularly with HBV DNA, ALT and HBsAg testing every 1-3 months and antiviral therapy should be initiated as soon as there is evidence of HBV reactivation, without waiting for a rise in ALT.<sup>35, 275</sup>

Vaccination of isolated anti-HBc-positive patients with a single dose of HBV vaccine can be considered. Antiviral prophylaxis may be more strongly indicated in those who remain with isolated anti-HBc than in those who develop an anti-HBs response.<sup>288</sup>

### HBsAg-negative, anti-HBc negative patients.

Prophylaxis is not required.

All patients undergoing cytotoxic / immunosuppressive therapy should be checked routinely for HBV serologic markers and serum HBV DNA levels.

## Liver Transplant Patients

Liver transplantation is used to treat end-stage CHB liver disease. Reactivation of HBV infection after transplantation in HBsAg carriers may be fatal. Mortality in the pre-HBIG era was high with a 5-year survival rate of between 40 and 60%.<sup>289</sup>

### Goal of Therapy

The principal goal of treatment is to decrease disease progression, prevent HCC and reinfection post-transplant. To achieve this, treatment objectives are:

1. Undetectable HBV DNA by PCR
2. ALT within normal limits

### Treatment Considerations

All patients awaiting transplantation should be immunised against HBV, although the likelihood of an effective antibody response is low.<sup>290</sup> Recipients with documented seroconversion following HBV immunisation and persistent protective levels of anti-HBs (>10 IU/mL) do not require antiviral prophylaxis.<sup>291</sup>

**HBeAg negative, HBV DNA negative.**

No treatment is necessary prior to liver transplantation. HCC screening with alpha-fetoprotein levels and imaging of the liver every 6 months is recommended.

**High-risk group (HBeAg-positive, HBV DNA+ detectable).** In order to prevent HBV recurrence post- liver transplantation and to keep viral replication to the lowest possible level at the time of surgery, patients should be commenced on antiviral therapy at the time of placement on the transplant waiting list (if not before) and started on combination lamivudine plus Hepatitis B Immunoglobulin (HBIG) during the anhepatic phase or immediately post-operatively.<sup>292</sup>

Life-long combination prophylaxis with low-dose intramuscular HBIG and lamivudine is effective in preventing recurrent HBV, may protect against the emergence of resistant mutants, and is significantly more cost-effective than HBIG monotherapy or high dose HBIG combination therapy.<sup>293, 294</sup>

Resistance occurs more frequently, and at an earlier time point in the transplantation setting<sup>295-297</sup> with immunosuppressed patients.<sup>298-301</sup> In patients with YMDD mutations and evidence of viral reactivation combination of lamivudine and adefovir, or the latter alone, is recommended.<sup>114, 193, 302-304</sup>

Recipients of other organs (e.g. kidney, lung) should receive lamivudine prophylaxis for at least the first post-transplant year during which time immunosuppression levels are at their highest.<sup>283, 305, 306</sup>

**Low-risk group (HBeAg-Negative, HBV DNA-negative).** HBIG should be initiated during the anhepatic phase. Lamivudine and/or adefovir (in presence of YMDD mutations) should be given starting the day of the transplant and both monthly intramuscular low dose HBIG and an antiviral drug should be given indefinitely.

**HBsAg-negative, HBV DNA-negative, anti-HBc positive, anti-HBs positive.** No treatment is necessary prior to transplant since the risk of recurrence is very low.<sup>307, 308</sup>

**Post-transplantation.** After twelve months post-transplantation switch to a combination of ADV/LAM which can provide effective prophylaxis against recurrence, equivalent to that provided by ongoing HBIG/LAM therapy.

Furthermore, combination ADV/LAM therapy is less expensive and is less burdensome to patients.

## Pregnancy/Lactation

Women with CHB generally do well during pregnancy providing they have not progressed to decompensated cirrhosis. While there are case reports and studies indicating an increased incidence of maternal and neonatal morbidity (e.g. premature delivery, raised incidence of antepartum haemorrhage, foetal distress, meconium peritonitis, gestational diabetes),<sup>309-314</sup> as a general rule, a stable liver equals a safe pregnancy.<sup>315</sup>

HBsAg-positive women who become pregnant may continue antiviral treatment only if the potential benefit of treatment outweighs the risk to the foetus. Careful consideration should be given to discontinuing pegIFN/interferon (Category B3) and nucleoside analogue therapy (Category B3) unless treatment is absolutely indicated. Given the uncertainties regarding foetal risks, no clear recommendations on treatment can be made at this time.

Mother to child transmission occurs through exposure to blood or blood contaminated fluids at, or around, the time of birth. The risk of perinatal transmission is associated with the HBeAg status of the mother. If a mother is positive for both HBsAg and HBeAg, 70% to 90% of her children become chronically infected.<sup>316, 317</sup> If a mother is HBsAg-positive but HBeAg-negative the risk of transmission is significantly lower.<sup>318-320</sup>

**HBsAg screening.** All pregnant women should be screened for HBsAg, even if previously tested or vaccinated.

**Modes of delivery.** Although elective caesarean delivery has been proposed as a means of reducing mother to child transmission,<sup>321</sup> the mode of delivery does not appear to have a significant effect on vertical transmission.<sup>322</sup>

**Management of infants.** All infants born to HBsAg positive women should receive hepatitis B vaccine and HBIG (0.5 mL)  $\leq$  12 hours of birth, administered at different injection sites.<sup>323-326</sup> HBIG and concurrent hepatitis B vaccine have been shown to be 95% efficacious in the prevention of perinatal transmission of HBV.<sup>327</sup> The evidence on immunisation for infants of HBsAg-positive mothers is strong and there is

no clear effect of the mother's HBeAg status on immunisation success.<sup>325</sup> In general, the risk of perinatal transmission from HBeAg-negative mothers is lower than from mothers who are HBeAg-positive.<sup>318, 320, 328</sup> but this should not affect the decision to immunise.

**Management of pregnant women with high viral loads.** The efficacy of HBIG and the hepatitis B vaccine may be lower in mothers with very high serum HBV DNA levels (>8 log IU/mL) at the time of delivery.<sup>326, 329</sup> In these patients there is limited evidence to suggest lamivudine, taken in the last month of pregnancy, may reduce high viral load and reduce, but not eliminate, the risk of child vaccination breakthrough.<sup>330-332</sup>

At this stage the routine use of antiviral agents during the third trimester of pregnancy to reduce the risk of vertical transmission in pregnant women with high levels of HBV DNA is not supported by available evidence.

**Breastfeeding.** HBsAg-positive mothers are encouraged to breastfeed their babies.<sup>333</sup> While HBV has been isolated in breast milk,<sup>334</sup> the risk of HBV transmission is very low and comparable for both breast-fed and formula-fed infants.<sup>333, 335-338</sup> Transmission may be more common in women with the HBeAg.<sup>339, 340</sup> It is recommended that the baby breastfeeds after the administration of the HBIG.<sup>324, 333</sup>

As the virus is most commonly passed by blood-to-blood routes, breastfeeding should be avoided if the mother has cracked or bleeding nipples.

## 13 REFERENCES

1. Lavanchy D. Worldwide epidemiology of HBV infection, disease burden, and vaccine prevention. *J Clin Virol* 2005;Dec 34 (Suppl 1):S1-3.
2. Lavanchy D. Hepatitis B virus epidemiology, disease burden, treatment, and current and emerging prevention and control measures. *J Viral Hepat* 2004;11:97-107.
3. McMahon B, ed. Hepatocellular carcinoma and viral hepatitis. New York: Marcel Dekkar; 1997.
4. Lai C. Therapeutic advances in chronic hepatitis B *J Gastro Hepatol* 2004;19:S5-S9.
5. Beasley R. Hepatitis B virus: the major etiology of hepatocellular carcinoma. *Cancer* 1988;61:1942-56.
6. WHO. Hepatitis B: fact sheet WHO/204 2000.
7. O'Sullivan B, Gidding, Law M, et al. Estimates of chronic hepatitis B virus infection in Australia, 2000. *Aust NZ J Public Health* 2004;28(3):2126.
8. Hepatitis B vaccination. 2005. (Accessed at <http://www.phaa.net.au/policy/HepBF.htm>.)
9. Australian Institute of Health and Welfare, ed. *Australias Health 2006*. AIHW cat no. AUS 73. Canberra: AIHW; 2006.
10. Gardner I, Wan X, Simms P, Worswick D, Burrell C, Mathews J. Hepatitis B virus markers and staff in Northern Territory schools. *Med J Aust* 1992;156:638-41.
11. Burrell C, Cameron A, Hart G, et al. Hepatitis B reservoirs and attack rates in an Australian community. A basis for vaccination and cross-infection policies. *Med J Aust* 1983;2:492-6.
12. Holman C, Bucens M, Quadros C, Reid P. Occurrence and distribution of hepatitis B infection in the Aboriginal population of Western Australia. *Aust NZ J Med* 1987;17:518-25.
13. Campbell D, Sargent J, Plant A. The prevalence of markers of infection with hepatitis B virus in a mixed race Australian community. *Med J Aust* 1989;150:489-92.
14. National Centre for Immunisation Research and Surveillance of Vaccine Preventable Diseases. Vaccine preventable diseases and vaccination coverage in Aboriginal and Torres Strait Islander people, Australia, 1999 to 2002. *Commun Dis Intell* 2004;28(Suppl 1).
15. Kaldor J, Plant A, Thompson S, Longbottom H, Rowbottom J. The incidence of hepatitis B infection in Australia: an epidemiological review. *Med J Aust* 1996;165:322-6.
16. Tawk H, Vickery K, Bisset L, et al. The current pattern of hepatitis B virus infection in Australia. *Journal of Viral Hepatitis* 2006;13:206 - 15.
17. Dore G, Wallace J, Locarnini S, Desmond P, Gane E, Crawford D. ACT-HBV Hepatitis B in Australia: Responding to a Diverse Epidemic. 2004.
18. Nguyen V, Razali K, Amin J, Law M, Dore G. Estimates and projections of hepatitis B-related hepatocellular carcinoma in Australia among people born in Asia-Pacific countries. *J Gastro Hepatol* 2007.
19. Gane E. Screening for chronic hepatitis B infection in New Zealand: unfinished business. *NZMJ* 2005;118(1211):1344.
20. Robinson T, Bullen C, Humphries W, Hornell J, Moyes C. The New Zealand Hepatitis B Screening Programme: screening coverage and prevalence of chronic hepatitis B infection. *NZMJ* 2005;118(1211):U1345.
21. Wilson N, Baker M. Acute hepatitis B resulting in hospitalisation in New Zealand. *NZMJ* 1996;109:54-5.
22. Blakely T, Salmond C, Tobias M. Hepatitis B virus carrier prevalence in New Zealand: Population estimates using the 1987 police and customs personnel survey. *NZMJ* 1998;111:142-4.
23. Lok A, McMahon B. Chronic hepatitis B. *Hepatology* 2007;45(2):507-39.
24. Holden S, Fraser M, Glass A, Kidson B, Levy M. Chronic HBV infection in SSWAHS; antenatal screening detects high rates of previously unrecognised cases. *J Gastro Hepatol* 2007;Abstract October.

25. Lin S, Chang E, So S. Why should we routinely screen Asian American adults for hepatitis b: a cross sectional study of Asians in California. *Hepatology* 2007;46:1034-40.
26. Hutton D, Tan D, Samuel S, Brandeau M. Cost Effectiveness of Screening and Vaccination Asian and Pacific Islander Adults for Hepatitis B. *Ann Intern Med* 2007;147(7):460-9.
27. Perrillo R. Acute flares in chronic hepatitis B: the natural and unnatural history of an immunologically mediated liver disease. *Gastroenterology* 2001;120:1009-22.
28. Fattovich G. Natural history and prognosis of hepatitis B. *Semin Liver Dis* 2003;23:47-58.
29. McMahon B. The natural history of chronic hepatitis B virus infection. *Semin Liver Dis* 2004;24(Suppl 1):17-21.
30. Lok A, Heathcote E, Hoofnagle J. Management of hepatitis B: 2000—summary of a workshop. *Gastroenterology* 2001;120:1828-53.
31. de Franchis R, Hadengue A, Lau G, et al. EASL International Consensus Conference on Hepatitis B. *J Hepatol* 2003;39 (Suppl 1):S3-S25.
32. Blackberg J, Kidd-Ljunggren K. Occult hepatitis B virus after acute selflimited infection persisting for 30 years without sequence variation. *J Hepatol* 2000;33:992-7.
33. Rehermann B, Ferrari C, Pasquinelli C, Chisari F. The hepatitis B virus persists for decades after patients' recovery from acute viral hepatitis despite active maintenance of a cytotoxic T-lymphocyte response. *Nat Med* 1996;2:1104-8.
34. Shimizu D, Nomura K, Matsumoto Y, et al. Hepatitis B virus reactivation in a patient undergoing steroid-free chemotherapy. *World J Gastroenterol* 2004;10:2301-2.
35. Lok A, Liang R, Chiu E, Wong K, Chan T, Todd D. Reactivation of hepatitis B virus replication in patients receiving cytotoxic therapy: report of a prospective study. *Gastroenterology* 1991;100:182-8.
36. Hui C-K, Leung N, Yuen S-T, et al. Natural history and disease progression in Chinese chronic hepatitis B patients in immune-tolerant phase. *Hepatology* 2007; 46(2):395-401.
37. Hoofnagle J, Dusheiko G, Seeff L, et al. Seroconversion from hepatitis B e antigen to antibody in chronic type B hepatitis. *Ann Intern Med* 1981;94:744-8.
38. Fattovich G, Rugge M, Brollo L, et al. Clinical, virologic and histologic outcome following seroconversion from HBeAg to anti-HBe in chronic hepatitis type B. *Hepatology* 1986;6:167-72.
39. Manno M, Camma C, Schepis F, et al. Natural history of chronic HBV carriers in northern Italy: morbidity and mortality after 30 years. *Gastroenterology* 2004;127:756-63.
40. Lok A, Lai C, Wu P, Leung E, Lam T. Spontaneous hepatitis e antigen to antibody seroconversion and reversion in Chinese patients with chronic hepatitis B virus infection. *Gastroenterology* 1987;92:1839-43.
41. Manesis E, Papatheodoridis G, Hadziyannis S. Serum HBV-DNA levels in inactive hepatitis B virus carriers. *Gastroenterology* 2002;122:2092-3.
42. Hsu Y-S, Chien R-N, Yeoh C-T, Sheen I, Chiou H, Liaw Y. Long-term outcome after spontaneous HBeAg seroconversion in patients with chronic hepatitis B. *Hepatology* 2002;35:1522-7.
43. Brunetto M, Oliveri F, Coco B, et al. The outcome of anti-HBe positive chronic hepatitis B in alpha-interferon treated and untreated patients: a long term cohort study. *J Hepatol* 2002;36:263-70.
44. Hadziyannis S. Hepatitis B e antigen negative chronic hepatitis B: from clinical recognition to pathogenesis and treatment. *Viral Hepatitis Reviews* 1995;1:7-36.
45. Hadziyannis S, Vassilopoulos D. Hepatitis B e antigen-negative chronic hepatitis B. *Hepatology* 2001;34(4 Pt 1):617-24.

46. Fattovich G, Olivari N, Pasino M, D'Onofrio M, Martone E, Donato F. Long-term outcome of chronic hepatitis B in Caucasian patients: mortality after 25 years. *Gut* 2008;57(1):84-90.
47. Chen C, Iloeje U, Yang H. Long-Term Outcomes in Hepatitis B: The REVEAL-HBV Study. *Clinics in Liver Disease* 2007;11(4):797-816.
48. Chen C, Yang H, Su J, et al. Risk of hepatocellular carcinoma across a biological gradient of serum hepatitis B virus DNA level. *JAMA* 2006;295(1):65-73.
49. Iloeje U, Yang H, Su J, Jen C, You S, Chen C. Predicting Cirrhosis Risk Based on the Level of Circulating Hepatitis B Viral Load. *Gastroenterology* 2006;130(3):678-86.
50. Papatheodoridis G, Chrysanthos N, Hadziyannis E, Cholongitas E, Manesis E. Longitudinal changes in serum HBV DNA levels and predictors of progression during the natural course of HBeAg-negative chronic hepatitis B virus infection. *J Viral Hepat* 2008;15(6):434-41.
51. Yuen M, Yuan H, Wong D, et al. Prognostic determinants for chronic hepatitis B in Asians: therapeutic implications. *Gut* 2005;54:1610-4.
52. Lai M, Hyatt B, Nasser I, Curry M, Afdhal N. The clinical significance of persistently normal ALT in chronic hepatitis B infection. *Journal of Hepatology* 2007;47(6):760-7.
53. Lin C, Liao L, Liu C, et al. Hepatitis B viral factors in HBeAg-Negative carriers with persistently normal serum alanine aminotransferase levels. *Hepatology* 2007;45(5):1193-8.
54. Kim H, Nam C, Jee S, Han K, Oh D, Suh I. Normal serum aminotransferase concentration prospective cohort study and risk of mortality from liver diseases. *BMJ* 2004;328:983-899.
55. Yim H, Lok A. Natural History of Chronic Hepatitis B Virus Infection: What We Knew in 1981 and What We Know in 2005. *Hepatology* 2006;43:S173-S81.
56. McMahon B, Holck P, Bulkow L, Snowball M. Serologic and clinical outcomes of 1536 Alaska Natives chronically infected with hepatitis B virus. *Ann Intern Med* 2001;135:759-68.
57. Fattovich G, Giustina G, Schalm S, et al. Occurrence of hepatocellular carcinoma and decompensation in Western European patients with cirrhosis type B. *Hepatology* 1995;21:77-82.
58. Lok A, McMahon B. Chronic hepatitis B: update of recommendations. *Hepatology* 2004;39:857-61.
59. EASL. Consensus statement (long version). In: EASL International Consensus Conference on Hepatitis B; 2003 13-14 September 2002; Geneva, Switzerland: J Hepatol; 2003. p. S3-S25.
60. Liaw Y-F, Leung N, Guan R, Lau R, Lau G, Merican I. Asia Pacific consensus statement on the management of chronic hepatitis B: an update. *J Gastro Hepatol* 2003;18:239-45.
61. Keeffe E, Dieterich D, Han S-H, et al. A treatment algorithm for the management of chronic hepatitis B virus infection in the United States. *Clin Gastroenterol Hepatol* 2004;2:87-106.
62. Hadziyannis S, Papatheodoridis G, Vassilopoulos D. Treatment of HBeAg-negative chronic hepatitis B. *Semin Liver Dis* 2003;23:81-8.
63. Wong D, Cheung A, O'Rourke K, Naylor C, Detsky A, Heathcote J. Effect of alpha-interferon treatment in patients with hepatitis B e antigen-positive chronic hepatitis B. *Ann Intern Med* 1993;119:312-23.
64. Cooksley W, Piratvisuth T, Lee S, et al. Peginterferon a-2a (40kDa): an advance in the treatment of hepatitis B e antigen-positive chronic hepatitis B. *J Viral Hepat* 2003;10:298-305.
65. Lau G, Piratvisuth T, Luo K, et al. PEGinterferon alfa-2a, lamivudine, and the combination for HBeAg-positive chronic hepatitis B. *N Engl J Med* 2005;352:2682-95.
66. Marcellin P, Lau G, Bonino F, et al. Peginterferon alfa-2a alone, lamivudine alone, and the two in combination in patients with HBeAg-negative chronic hepatitis B. *N Engl J Med* 2004;351(12):1206-17.
67. Janssen H, van Zonneveld M, Senturk H, et al. Pegylated interferon alfa-2b alone or in combination with lamivudine for HBeAg-

- positive chronic hepatitis B: a randomised trial. *Lancet* 2005;365(9454):123-9.
68. Dienstag J, Schiff E, Wright T, et al. Lamivudine as Initial Treatment for Chronic Hepatitis B in the United States. *N Engl J Med* 1999;341:1256-63.
  69. Lai C, Chien R, Leung N, et al. A one-year trial of lamivudine for chronic hepatitis B. Asia Hepatitis Lamivudine Study Group. *N Engl J Med* 1998;339:61-8.
  70. Marcellin P, Chang T-T, Lim S, et al. Adefovir Dipivoxil for the Treatment of Hepatitis B e Antigen-Positive Chronic Hepatitis B. *N Engl J Med* 2003;348:808-16.
  71. Hadziyannis S, Tassopoulos N, Heathcote E, et al. Adefovir Dipivoxil for the Treatment of Hepatitis B e Antigen-Negative Chronic Hepatitis B. *N Engl J Med* 2003;348:800-7.
  72. Hadziyannis S, Tassopoulos N, Heathcote E, et al. Long-Term Therapy with Adefovir Dipivoxil for HBeAg-Negative Chronic Hepatitis B. *N Engl J Med* 2005;352:2673-81.
  73. Lai C, Shouval D, Lok A, Chang T, et al, for the BEHoLD A1463027 Study Group. Entecavir versus Lamivudine for Patients with HBeAg-Negative Chronic Hepatitis B. *N Engl J Med* 2006;354:1011-20.
  74. Chang T, Gish R, de Man R, Gadano A, et al, for the A1463022 BEHoLD Study Group. A Comparison of Entecavir and Lamivudine for HBeAg-Positive Chronic Hepatitis B. *N Engl J Med* 2006;354:1001-10.
  75. Niederau C, Heintges T, Lange S, et al. Long-term follow-up of HBeAg-positive patients treated with interferon alfa for chronic hepatitis B. *N Engl J Med* 1996;334:1422-7.
  76. Lau D, Everhart J, Kleiner D, et al. Long-term follow up of patients with chronic hepatitis B treated with interferon-alfa. *Gastroenterology* 1997;113:1660-7.
  77. van Zonneveld M, Honkoop P, Hansen B, et al. Long-term follow-up of alpha-interferon treatment of patients with chronic hepatitis B. *Hepatology* 2004;39:804-10.
  78. Lok A, Chung H, Liu V, Ma O. Long-term follow-up of chronic hepatitis B patients treated with interferon alfa. *Gastroenterology* 1993;105:1833-8.
  79. Song B, Suh D, Lee H, Chung Y, Lee Y. Hepatitis B e antigen seroconversion after lamivudine therapy is not durable in patients with chronic hepatitis B in Korea. *Hepatology* 2000;32:803-6.
  80. Park B, Park Y, Ahn S, et al. Long-term outcome of chronic hepatitis B based on histological grade and stage. *J Gastro and Hepatol* 2007;22(3):383-8.
  81. Yu M, Hsu F, Sheen I, et al. Prospective Study of Hepatocellular Carcinoma and Liver Cirrhosis in Asymptomatic Chronic Hepatitis B Virus Carriers. *Am J Epidemiol* 1997;145(11):1039-47.
  82. Lai C, Dienstag J, Schiff E, et al. Prevalence and clinical correlates of YMDD variants during lamivudine therapy for patients with chronic hepatitis B. *Clin Infect Dis* 2003;36:687-96.
  83. MIMS Prescribing Information. In; 2008.
  84. Medsafe. Hepsera NZ Data Sheet. 2008.
  85. van Bömmel F, De Man R, Erhardt A, et al. First Multi-centre Evaluation of Efficacy of Tenofovir in Nucleoside/ tide Analog Experienced Patients with HBV mono-infection #83. In: AASLD. Boston MA; 2007.
  86. Takeda A, Jones J, Shepherd J, Davidson P, Price A. A systematic review and economic evaluation of adefovir dipivoxil and pegylated interferon-alpha-2a for the treatment of chronic hepatitis B. *J Viral Hepat* 2007;14(2):75-88.
  87. van Zonneveld M, Flink H, Verhey E, et al. The safety of pegylated interferon alpha-2b in the treatment of chronic hepatitis B: predictive factors for dose reduction and treatment discontinuation. *Aliment Pharmacol Ther* 2005;21(9):1163-71.
  88. Flink H, Sprengers D, Hansen B, et al. Flares in chronic hepatitis B patients induced by the host or the virus? Relation to treatment response during peg-interferon {alpha}-2b therapy. *Gut* 2005;54:1604-9.
  89. Keeffe E, Zeuzem S, Koff R, et al. Report of an international workshop: Roadmap for management of patients receiving oral therapy for chronic hepatitis B. *Clin Gastroenterol Hepatol* 2007;5(8):890-7.

90. Lai C, et al. A 1-year trial of telbivudine, lamivudine, and the combination in patients with hepatitis B e antigen-positive chronic hepatitis B. *Gastroenterology* 2005;129:528-36.
91. Locarnini S, Qi X, Arterburn S, et al. Incidence and predictors of emergence of adefovir resistant HBV during four years of adefovir dipivoxil (ADV) therapy for patients with chronic hepatitis B (CHB). *J Hepatol* 2005;42(Suppl 2):A36.
92. Yuen M, Sablon E, Hui C, Yuan H, Decraemer H, Lai C. Factors preceding with hepatitis B virus DNA breakthrough in patients receiving prolonged lamivudine therapy. *Hepatology* 2001;34:785-91.
93. Hadziyannis S, Tassopoulos E, Heathcote J, et al. Long-term Therapy With Adefovir Dipivoxil for HBeAg-Negative Chronic Hepatitis B for up to 5 Years *Gastroenterology* 2006;131(6):1743-51
94. Rapti I, Dimou E, Mitsoula P, Hadziyannis S. Adding-on versus switching-to adefovir therapy in lamivudine-resistant HBeAg-negative chronic hepatitis B. *Hepatology* 2007;45(2):307-13.
95. Lai C, Gane E, Liaw Y, et al. Telbivudine versus Lamivudine in Patients with Chronic Hepatitis B. *N Engl J Med* 2007;357(25):2576-88.
96. Di Bisceglie A, Lai C, Gane E, et al. Telbivudine GLOBE trial: maximal early HBV suppression is predictive of optimal two-year efficacy in nucleoside-treated hepatitis B patients. *Hepatology* 2006;44:230A.
97. ter Borg M, van Zonneveld M, Zeuzem S, et al. Patterns of viral decline during PEG-interferon alpha-2b therapy in HBeAg-positive chronic hepatitis B: Relation to treatment response. *Hepatology* 2006;44(3):721-7.
98. Marcellin P, Buti M, Krastev Z, et al. A Randomized, Double-Blind, Comparison of Tenofovir DF (TDF) versus Adefovir Dipivoxil (ADV) for the Treatment of HBeAg-Negative Chronic Hepatitis B (CHB): Study GS-US-174-0102 In: AASLD. Boston MA; 2007.
99. Heathcote E, Gane E, De Man R, et al. A randomized, double-blind, comparison of tenofovir DF (TDF) versus adefovir dipivoxil (ADV) for the treatment of HBeAg-positive chronic hepatitis B (CHB). *Hepatology* 2007;46:S861A.
100. Flink H, van Zonneveld M, Hansen B, et al. Treatment with Peg-interferon alpha-2b for HBeAg-positive chronic hepatitis B: HBsAg loss is associated with HBV genotype. *Am J Gastroenterol* 2006 101(2):297-303.
101. Buster E, Flink H, Cakaloglu Y, et al. Sustained HBeAg and HBsAg Loss After Long-term Follow-up of HBeAg-Positive Patients Treated With Peginterferon alpha-2b. *Gastroenterology* 2008;135(2):459-67.
102. Yuen M, Wong D, Yuan H, Sum S, Lai C. HBsAg seroclearance in Chinese patients receiving lamivudine therapy for chronic hepatitis B virus infection. *J Clin Microbiol* 2004;42:4882-4.
103. Liaw Y, Sung J, Chow W, et al. Lamivudine for patients with chronic hepatitis B and advanced liver disease. *N Engl J Med* 2004;351:1521-31.
104. Leung N, Lai C, Chang T, et al. Extended lamivudine treatment in patients with chronic hepatitis B enhances hepatitis B e antigen seroconversion rates: results after 3 years of therapy. *Hepatology* 2001;33:1527-32.
105. Liaw Y, Leung N, Chang T, et al. Effects of extended lamivudine therapy in Asian patients with chronic hepatitis B. *Gastroenterology* 2000;119:172-80.
106. Yuen M, Yuan H, Hui C, et al. A large population study of spontaneous HBeAg seroconversion and acute exacerbation of chronic hepatitis B infection: implications for antiviral therapy. *Gut* 2003;52(3):416-9.
107. Yoon S, Jang J, Kim C, et al. Long-Term Results of Lamivudine Monotherapy in Korean Patients with HBeAg-Positive Chronic Hepatitis B: Response and Relapse Rates, and Factors Related to Durability of HBeAg Seroconversion. *Intervirology* 2005;48(6):341-9.

108. Chang T, Lai C, Chien R, et al. Four years of lamivudine treatment in Chinese patients with chronic hepatitis B. *J Gastroenterol Hepatol* 2004;19(11):1276-82.
109. Lok A, Lai C, Leung N, et al. Long-term safety of lamivudine treatment in patients with chronic hepatitis B. *Gastroenterology* 2003;125:1714-22.
110. Dienstag J, Goldin R, Heathcote E, et al. Histological outcome during long-term lamivudine therapy. *Gastroenterology* 2003;124:105-17.
111. Schalm S, Heathcote J, Cianciara J, et al. Lamivudine and alpha interferon combination treatment of patients with chronic hepatitis B infection: a randomised trial. *Gut* 2000;46:562-8.
112. Shepherd J, Jones J, Takeda A, Davidson P, Price A. Adefovir dipivoxil and pegylated interferon alfa-2a for the treatment of chronic hepatitis B: a systematic review and economic evaluation. *Health Technology Assessment* 2006;10(28).
113. Marcellin P, Chang T, Lim S, et al. Long-term efficacy and safety of adefovir dipivoxil for the treatment of hepatitis B e antigen-positive chronic hepatitis B. *Hepatology* 2008;48(3):750-8.
114. Perrillo R, Hann H, Mutimer D, et al. Adefovir dipivoxil added to ongoing lamivudine in chronic hepatitis B with YMDD mutant hepatitis B virus. *Gastroenterology* 2004;126(1):81-90.
115. Peters M, Harm H, Martin P, et al. Adefovir dipivoxil alone and in combination with lamivudine in patients with lamivudine-resistant chronic hepatitis B. *Gastroenterology* 2004;126:91-101.
116. Leung N, Sherman N, Peng C, et al. Abstract: Entecavir (ETV) Results in Higher HBV- DNA Reduction vs Adefovir (ADV) in Chronically Infected HBeAg+ Antiviral-Naive Adults: 48-Week Results (E.A.R.L.Y. Study). In: *Digestive Disease Week (DDW)*. Washington, DC; 2007.
117. Zeng M, Mao Y, Yao G, et al. A Double-Blind Randomized Trial of Adefovir Dipivoxil in Chinese Subjects With HBeAg-Positive Chronic Hepatitis B. *Hepatology* 2006;44(1):108-16.
118. Angus P, Vaughan R, Xiong S, et al. Resistance to adefovir dipivoxil therapy associated with the selection of a novel mutation in the HBV polymerase. *Gastroenterology* 2003;125:292-7.
119. Gish R, Lok A, Chang T, et al. Entecavir Therapy for up to 96 Weeks in Patients With HBeAg-Positive Chronic Hepatitis B. *Gastroenterology* 2007;133(5):1437-44.
120. Sherman M, Yurdaydin C, Simsek H, et al. Entecavir therapy for lamivudine-refractory chronic hepatitis B: Improved virologic, biochemical, and serology outcomes through 96 weeks. *Hepatology* 2008;48(1):99-108.
121. Colonno R, Rose R, Baldick C, et al. Entecavir resistance is rare in nucleoside naïve patients with hepatitis B. *Hepatology* 2006;44(6):1656-65.
122. Tenney D, Pokorowski K, Rose R, et al. Entecavir at Five Years Shows Long Long-Term Maintenance of High Genetic Barrier to Hepatitis B Virus Resistance In: *Conference of the Asia-Pacific Association for the Study of the Liver (APASL)*. Seoul, Korea; 2008.
123. Lai C, Gane E, Hsu C, et al. Two-year results from the GLOBE trial in patients with hepatitis B: greater clinical and antiviral efficacy for telbivudine (LdT) vs. lamivudine. *Hepatology* 2006;44(Suppl.1):222A.
124. van Bömmel F, Wünsche T, Mauss S, et al. Comparison of adefovir and tenofovir in the treatment of lamivudine-resistant hepatitis B virus infection. *Hepatology* 2004;40(6):1421-5.
125. Heathcote J, Gane E, DeMan R, et al. A Randomized, Double-Blind, Comparison of Tenofovir DF (TDF) versus Adefovir Dipivoxil (ADV) for the Treatment of HBeAg Positive Chronic Hepatitis B (CHB): Study GS-US-174-0103. In: *AASLD*. Boston MA; 2007.

126. Villet S, Pichoud C, Villeneuve J, Trepo C, Zoulim F. Selection of a multiple drug resistant hepatitis B virus strain in a liver transplanted patient. *Gastroenterology* 2006;131:1253-61.
127. Kaymakoglu S, Oguz D, Gur G, et al. Pegylated Interferon Alfa-2b Monotherapy and Pegylated Interferon Alfa-2b plus Lamivudine Combination Therapy for Patients with Hepatitis B Virus E Antigen-Negative Chronic Hepatitis B. *Antimicrob Agents Chemother* 2007;51(8):3020-2.
128. Bonino F, Marcellin P, Lau G, et al. Predicting response to peginterferon {alpha}-2a, lamivudine and the two combined for HBeAg-negative chronic hepatitis B. *Gut* 2007;56(5):699-705.
129. Hoofnagle J. Hepatitis B—preventable and now treatable. *N Engl J Med* 2006;345:1074-6.
130. Lai C, Gane E, Liaw Y, et al. Telbivudine versus lamivudine for chronic hepatitis B: first year results from the international phase III globe trial. *Hepatology* 2005;42(Suppl 1 LB01):748A.
131. Hadziyannis S, Papatheodoridis G, Dimou E, Laras A, Papaioannou C. Efficacy of long-term lamivudine monotherapy in patients with hepatitis B e antigen-negative chronic hepatitis B. *Hepatology* 2000;32:847-51.
132. Papatheodoridis G, Dimou E, Laras A, Papadimitropoulos V, Hadziyannis S. Course of virologic breakthroughs under long-term lamivudine in HBeAg-negative precore mutant HBV liver disease. *Hepatology* 2002;36:219-26.
133. Papatheodoridis G, Dimou E, Dimakopoulos K, et al. Outcome of hepatitis B e antigen-negative chronic hepatitis B on long-term nucleos(t)ide analog therapy starting with lamivudine. *Hepatology* 2005;42(1):121-9.
134. Gaia S, Marzano A, Smedile A, et al. Four years of treatment with lamivudine: clinical and virological evaluations in HBe antigen-negative chronic hepatitis B. 2004;20(3):281-7.
135. Di Marco V, Marzano A, Lampertico P, et al. Clinical outcome of HBeAg-negative chronic hepatitis B in relation to virological response to lamivudine. *Hepatology* 2004;40(4):883-91.
136. Fung S, Wong F, Hussain M, et al. Sustained response after a 2-year course of lamivudine treatment of hepatitis B e antigen-negative chronic hepatitis B. *J Viral Hepat* 2004;11:432-8.
137. Lampertico P, Viganò M, Manenti E, Iavarone M, Lunghi G, Colombo M. Adefovir rapidly suppresses hepatitis B in HBeAg-negative patients developing genotypic resistance to lamivudine. *Hepatology* 2005;42(6):1414-9.
138. Rizzetto M, Volpes R, Smedile A. Response of pre-core mutant chronic hepatitis B infection to lamivudine. *J Med Virol* 2000;61:398-400.
139. Santantonio T, Mazzola M, Iacovazzi T, Miglietta A, Guastadisegni A, Pastore G. Long-term follow-up of patients with anti-HBe/HBV DNA-positive chronic hepatitis B treated for 12 months with lamivudine. *J Hepatol* 2000;32:300-6.
140. Tassopoulos N, Volpes R, Pastore G, et al. Efficacy of lamivudine in patients with hepatitis B e antigen-negative/ hepatitis B virus DNA-positive (precore mutant) chronic hepatitis B. Lamivudine Precore Mutant Study Group. *Hepatology* 1999;29:889-96.
141. Locarnini S, Qi W, Arterburn S. Incidence and predictors of emergence of adefovir resistant HBV during four years of adefovir dipivoxil (ADV) therapy for patients with chronic hepatitis B (CHB) (abstract). *J Hepatol* 2005;42:17.
142. Pellicelli A, Barbaro G, Francavilla R, et al. Adefovir and lamivudine in combination compared with adefovir monotherapy in HBeAg-negative adults with chronic hepatitis B virus infection and clinical or virologic resistance to lamivudine: A retrospective, multicenter, nonrandomized, open-label study. *Clin Ther* 2008;30(2):317-23.
143. Shouval D, Hatzis G, Kitis G, et al. Continued virologic and biochemical improvement through 96 weeks of entecavir treatment in HBeAg(-) hepatitis B patients (Study ETV-027). *J Hepatol* 2006;44:S182.

144. Marcellin P, Buti M, Krastev Z, et al. A randomized, double-blind, comparison of tenofovir DF (TDF) versus adefovir dipivoxil (ADV) for the treatment of HBeAg-negative chronic hepatitis B (CHB). *Hepatology* 2007;46:S290A–S1A.
145. Nafa S, Ahmed S, Tavan D, et al. Early detection of viral resistance by determination of hepatitis B virus polymerase mutations in patients treated by lamivudine for chronic hepatitis B. *Hepatology* 2000;32:1078-88.
146. Locarnini S. Primary resistance, multidrug resistance, and cross-resistance pathways in HBV as a consequence of treatment failure. *Hepatol Int* 2008;2:147 - 51.
147. Zoulim F. Mechanism of viral persistence and resistance to nucleoside and nucleotide analogs in chronic hepatitis B virus infection. *Antiviral Research* 2004;64:1-15.
148. Zoulim F, Buti M, Lok A. Antiviral-resistant hepatitis B virus: can we prevent this monster from growing? *J Viral Hepat* 2007;14(Suppl 1):29-36.
149. Locarnini S. Identification of resistance with genotypic and phenotypic assays. In: EASL. Paris, France; 2008.
150. Lok A, Zoulim F, Locarnini S, et al. Antiviral drug-resistant HBV: Standardization of nomenclature and assays and recommendations for management. *Hepatology* 2007;46(1):254-65.
151. Seignerres B, Pichoud C, Martin P, Furman P, Trepo C, Zoulim F. Inhibitory activity of dioxolane purine analogs on wild-type and lamivudine-resistant mutants of hepadnaviruses. *Hepatology* 2002;36(710–722).
152. Delaney W, Ray A, Yang H, et al. Intracellular metabolism and in vitro activity of tenofovir against hepatitis B virus. *Antimicrob Agents Chemother* 2006;50:2471-7.
153. Allen M, Deslauriers M, Andrews C, et al. Identification and characterization of mutations in hepatitis B virus resistant to lamivudine. *Hepatology* 1998;27(6):1670-7.
154. Yang H, Qi X, A S, Miller M, Xiong S, Delaney W. Cross-resistance testing of next-generation nucleoside and nucleotide analogues against lamivudine-resistant HBV. *Antivir Ther* 2005;10:625-33.
155. Tenney D, Levine S, Rose R, et al. Clinical emergence of entecavir-resistant hepatitis B virus requires additional substitutions in virus already resistant to lamivudine. *Antimicrob Agents Chemother* 2004;48:3498-507.
156. Villet S, Ollivet A, Pichoud C, et al. Stepwise process for the development of entecavir resistance in a chronic hepatitis B virus infected patient. *J Hepatol* 2007;46:531-8.
157. Villeneuve J, Durantel D, Durantel S, et al. Selection of a hepatitis B virus strain resistant to adefovir in a liver transplantation patient. *J Hepatol* 2003;39:1085-9.
158. Qi X, Xiong S, Yang H, Miller M, Delaney W. In vitro susceptibility of adefovir-associated hepatitis B virus polymerase mutations to other antiviral agents. *Antivir Ther* 2007;12:355–62.
159. Gallant J. Drug resistance and the treatment of experienced patients. *Hopkins HIV Rep* 2002;14(5):1,5 -7,16.
160. Yim H, Hussain M, Liu Y, Wong S, Fung S, Lok A. Evolution of multi-drug resistant hepatitis B virus during sequential therapy. *Hepatology* 2006;44(3):703-12.
161. Leemans W, Niesters H, van der Eijk A, Janssen H, Schalm S, de Man R. Selection of an entecavir-resistant mutant despite prolonged hepatitis B virus DNA suppression, in a chronic hepatitis B patient with preexistent lamivudine resistance: successful rescue therapy with tenofovir. *European J Gastro Hepatol* 2008;28(8):773-7.
162. Brunelle M, Jacquard A, Pichoud C, et al. Susceptibility to antivirals of a human HBV strain with mutations conferring resistance to both lamivudine and adefovir. *Hepatology* 2005;41:1391-8.
163. Bartholomeusz A, Locarnini S. Antiviral drug resistance: clinical consequences and molecular aspects. *Semin Liver Dis* 2006;26(2):162-70.

164. Thompson A, Ayres A, Yuen L, et al. Lamivudine resistance in patients with chronic hepatitis B: Role of clinical and virological factors. *J Gastro Hepatol* 2007;22(7):1078-85.
165. Colonno R, Rose R, Pokornowski K, et al. Four year assessment of ETV resistance in nucleoside-naive and lamivudine refractory patients. Abstract 781. In: 42nd Annual Meeting of the European Association for the Study of the Liver. Barcelona, Spain; 2007.
166. Westland C, Yang H, Delaeny W, et al. Week 48 resistance surveillance in two phase 3 clinical studies of adefovir dipivoxil for chronic hepatitis B. *Hepatology* 2003;38:96-103.
167. Fung S, Chae H, Fontana R, et al. Virologic response and resistance to adefovir in patients with chronic hepatitis B. *J Hepatol* 2006;44(2):283-90.
168. Lee Y, Suh D, Lim Y, et al. Increased risk of adefovir resistance in patients with lamivudine-resistant chronic hepatitis B after 48 weeks of adefovir dipivoxil monotherapy. *Hepatology* 2006;43:1385-91.
169. Lampertico P, Viganò M, Manenti E, Iavarone M, Sablon E, Colombo M. Low resistance to adefovir combined with lamivudine: a 3-year study of 145 lamivudine-resistant hepatitis B patients. *Gastroenterology* 2007; 133:1445-51.
170. Richman D. The implications of drug resistance for strategies of combination antiviral chemotherapy. *Antiviral Res* 1996;29:31-3.
171. Locarnini S, Hatzakis A, Heathcote J, et al. Management of antiviral resistance in patients with chronic hepatitis B. *Antivir Ther* 2004;9:679-93.
172. Manolakopoulos S, Bethanis S, Koutsounas S, et al. Long-term therapy with adefovir dipivoxil in hepatitis B e antigen-negative patients developing resistance to lamivudine. *Alim Pharmacol Ther* 2008;27(3):266-73.
173. van der Poorten D, Prakoso E, Khoo T, et al. Combination adefovir-lamivudine prevents emergence of adefovir resistance in lamivudine-resistant hepatitis B. *J Gastroenterol Hepatol* 2007;22(9):1500-5.
174. Data on file.
175. Liaw Y, Lee C, Chien R, Yeh C. Switching to adefovir monotherapy after emergence of lamivudine-resistant mutations in patients with liver cirrhosis. *J Viral Hepat* 2006;13(4):250-5.
176. Chang T, Gish R, Hadziyannis S, et al. A dose-ranging study of the efficacy and tolerability of entecavir in Lamivudine-refractory chronic hepatitis B patients. *Gastroenterology* 2005;129:1198-209.
177. Tenney D, Rose R, Baldick C, et al. Two-Year Assessment of Entecavir Resistance in Lamivudine-Refractory Hepatitis B Virus Patients Reveals Different Clinical Outcomes Depending on the Resistance Substitutions Present. *Antimicrob Agents Chemother* 2007;51(3):902-11.
178. Fung S, et al. Adefovir-resistant hepatitis B can be associated with viral rebound and hepatic decompensation. *J Hepatol* 2005;43:937-43.
179. van Bommel F, Zollner B, Sarrazin C, et al. Tenofovir for patients with lamivudine-resistant hepatitis B virus (HBV) infection and high HBV DNA level during adefovir therapy. *Hepatology* 2006;44:318-25.
180. Choe W, Kwon S, Kim B, et al. Tenofovir plus lamivudine as rescue therapy for adefovir-resistant chronic hepatitis B in hepatitis B e antigen-positive patients with liver cirrhosis. *Liver Int* 2008;28(6):814-20.
181. Wursthorn K, Lutgehetmann M, Dandri M, et al. Peginterferon alpha-2b plus adefovir induce strong cccDNA decline and HBsAg reduction in patients with chronic hepatitis B. *Hepatology* 2006 Aug 29;44(3):675-84.
182. Fattovich G, Bortolotti F, Donato F. Natural history of chronic hepatitis B: Special emphasis on disease progression and prognostic factors. *Journal of Hepatol* 2008;48(2):335-52.

183. Fattovich G, Giustina G, Realdi G, Corrocher R, Schalm S, and the European Concerted Action of Viral Hepatitis (EUROHEP). Long-term outcome of hepatitis B e antigen-positive patients with compensated cirrhosis treated with interferon alfa. *Hepatology* 1997;26:1338-42.
184. Benhamou Y. Treatment algorithm for chronic hepatitis B in HIV-infected patients. *J Hepatol* 2006;44(Suppl. 1):S90-S4.
185. de Jongh F, Janssen H, de Man R, Hop W, Schalm S, van Blankenstein M. Survival and prognostic indicators in hepatitis B surface antigen-positive cirrhosis of the liver. *Gastroenterology* 1992;103:1630-5.
186. Donato F, Tagger A, Gelatti U, et al. Alcohol and hepatocellular carcinoma: the effect of lifetime intake and hepatitis virus infections in men and women. *Am J Epidemiol* 2002;155:323-31.
187. Iloeje U, Yang H, Su J, et al. Predicting cirrhosis risk based on the level of circulating hepatitis B viral load. *Gastroenterology* 2006;130:678-86.
188. Chu C, Liaw Y. Hepatitis B virus-related cirrhosis: natural history and treatment. *Semin Liver Dis* 2006 May;26(2):142-52.
189. Mallet V, Dhalluin-Venier V, Verkarre V, et al. Reversibility of cirrhosis in HIV/HBV coinfection. *Antivir Ther* 2007;12(2):279-83.
190. Villeneuve J, Condreay L, Willems B, et al. Lamivudine treatment for decompensated cirrhosis resulting from chronic hepatitis B. *Hepatology* 2000;31:207-10.
191. Sponseller C, Bacon B, Di Bisceglie A. Clinical improvement in patients with decompensated liver disease caused by hepatitis B after treatment with lamivudine. *Liver Transpl* 2000;6:715-20.
192. Kapoor D, Guptan R, Wakil S, et al. Beneficial effects of lamivudine in hepatitis B virus-related decompensated cirrhosis. *J Hepatol* 2000;33:308-12.
193. Schiff E, Lai C, Hadziyannis S, et al. Adefovir dipivoxil therapy for lamivudine-resistant hepatitis B in pre- and post-liver transplantation patients. *Hepatology* 2003;38:1419-27.
194. Hoofnagle J, Di Bisceglie A, Waggoner J, Park Y. Interferon alfa for patients with clinically apparent cirrhosis due to chronic hepatitis B. *Gastroenterology* 1993;104:1116-21.
195. Alter M. Epidemiology of viral hepatitis and HIV co-infection. *J Hepatol* 2006;44 (Suppl 1):S6 -9.
196. Iser D, Sasadeusz J. Current treatment of HIV/hepatitis B virus coinfection. *J Gastro and Hepatol* 2008;23(5):699-706.
197. Benhamou Y. Hepatitis B in the HIV-Coinfected Patient. *J AIDS* 2007;45 (Suppl. 2):S57-S65.
198. Thio C, Seaberg E, Skolasky RJ, et al. Multicenter AIDS Cohort Study. HIV-1, hepatitis B virus, and risk of liver-related mortality in the Multicenter Cohort Study (MACS). *Lancet* 2002;360:1921-6.
199. Konopnicki D, Mocroft A, de Wit S, et al. Hepatitis B and HIV: prevalence, AIDS progression, response to highly active antiretroviral therapy and increased mortality in the EuroSIDA cohort. *AIDS* 2005;19(6):593 - 601.
200. Brook M, Gilson R, Wilkins E. BHIVA guidelines on HIV and chronic hepatitis: coinfection with HIV and hepatitis B virus infection (2005). *HIV Med* 2005;6:84-95.
201. Alberti A, Clumeck N, Collins S, et al. Short Statement of the first European Consensus Conference on the Treatment of Chronic Hepatitis B and C in HIV Co-infected Patients. *J Hepatol* 2005;42(5):615-24.
202. Treating opportunistic infections among HIV-infected adults and adolescents. 2004. (Accessed February 16, 2006, at <http://www.cdc.gov/mmwr/preview/mmwrhtml/rr5315a1.htm>.)
203. Supplement to the Guidelines for the Use of Antiretroviral Agents in HIV-1-Infected Adults and Adolescents 2006. (Accessed April 2007, at [www.aidsinfo.nih.gov](http://www.aidsinfo.nih.gov).)
204. McMahon M, Jilek B, Brennan T. The HBV Drug Entecavir - Effects on HIV-1 Replication and Resistance. *N Engl J Med* 2007;356(25):2614-21.

205. DHHS Panel on Antiretroviral Guidelines for Adults and Adolescents – A Working Group of the Office of AIDS Research Advisory Council (OARAC). Guidelines for the Use of Antiretroviral Agents in HIV-1-Infected Adults and Adolescents. 2006.
206. Benhamou Y, Fleury H, Trimoulet P, et al. Anti-hepatitis B virus efficacy of tenofovir disoproxil fumarate in HIV-infected patients. *Hepatology* 2006;43(3):548-55.
207. Dore G, Cooper D, Pozniak A, et al. Efficacy of Tenofovir Disoproxil Fumarate in Antiretroviral Therapy Naive and Experienced Patients Coinfected with HIV-1 and Hepatitis B Virus. *J Infect Dis* 2004;189:1185-92
208. Benhamou Y, Katlama C, Lunel F, et al. The effects of lamivudine on replication of hepatitis B virus in HIV-infected men. *Ann Intern Med* 1996;125:705-12.
209. Dore G, Cooper D, Barrett C, Goh L, Thakrar B, Atkins M. Dual efficacy of lamivudine treatment in human immunodeficiency virus/hepatitis B virus-co-infected persons in a randomized, controlled study (CAESAR). The CAESAR coordinating committee. *J Infect Dis* 1999;180:607-13.
210. Matthews G, Avihingsanon A, Lewin S, et al. A randomized study of tenofovir (TDF) containing HAART compared to lamivudine (LAM) containing HAART in antiretroviral (ARV) naïve HIV/HBV coinfecting patients in Thailand: 48 week findings (Abstract TUAB205). In: 4th International AIDS Society Conference on HIV Pathogenesis, Treatment and Prevention. Sydney, Australia; 2007.
211. Peters M, Andersen J, Lynch P, et al. Randomized controlled study of tenofovir and adefovir in chronic hepatitis B virus and HIV infection: ACTG A5127. *Hepatology* 2006;44(5):1110-6.
212. Bessesen M, Ives D, Condreay L, Lawrence S, Sherman K. Chronic active hepatitis B exacerbations in HIV-infected patients following development of resistance to or withdrawal of lamivudine. *Clin Infect Dis* 1999;285:1032-5.
213. Benhamou Y, Bochet M, Thibault V, et al. Long-term incidence of hepatitis B virus resistance to lamivudine in human immunodeficiency virus-infected patients. *Hepatology* 1999;30:1302-6.
214. Benhamou Y, Bochet M, Thibault V, et al. Safety and efficacy of adefovir dipivoxil in patients co-infected with HIV-1 and lamivudine-resistant hepatitis B virus: an open-label pilot study. *Lancet* 2001;358:718-23.
215. Benhamou Y, Thibault V, Calvez V, et al. 3-year treatment with adefovir dipivoxil in chronic hepatitis B patients with lamivudineresistant HBV/HIV co-infection, results in significant and sustained clinical improvement (abstr 835). In: XIth Conference on Retroviruses and Opportunistic Infections, 2004. San Francisco; 2004.
216. Benhamou Y, Thibault V, Vig P, et al. Safety and efficacy of adefovir dipivoxil in patients infected with lamivudine-resistant hepatitis B and HIV-1. *J Hepatol* 2005;44(1):62-7.
217. Ying C, De Clercq E, Nicholson W, Furman P, Neyts J. Inhibition of the replication of the DNA polymerase M550V mutation variant of human hepatitis B virus by adefovir, tenofovir, L-FMAU, DAPD, penciclovir and lobucavir. *J Viral Hepat* 2000;7(2):161-5.
218. Liaw Y. Role of hepatitis C virus in dual and triple hepatitis virus infection. *Hepatology* 1995;22:1101-8.
219. Zignego A, Fontana R, Puliti S, et al. Relevance of inapparent coinfection by hepatitis B virus in alpha interferon-treated patients with hepatitis C virus chronic hepatitis. *J Med Virol* 1997;51:313-8.
220. Fong T, Di Bisceglie A, Waggoner J, Banks S, Hoofnagle J. The significance of antibody to hepatitis C virus in patients with chronic hepatitis B. *Hepatology* 1991;14:64-7.
221. Zarski J, Bohn B, Bastie A, et al. Characteristics of patients with dual infection by hepatitis B and C viruses. *J Hepatol* 1998;28:27-33.

222. Kaklamani E, Trichopoulos D, Tzonou A, et al. Hepatitis B and C viruses and their interaction in the origin of hepatocellular carcinoma. *JAMA* 1991;265:1974–6.
223. Benvegna L, Fattovich G, Noventa F, et al. Concurrent hepatitis B and C virus infection and risk of hepatocellular carcinoma in cirrhosis. A prospective study. *Cancer* 1994;74:2442–8.
224. Mohamed Ael S, al Karawi M, Mesa G. Dual infection with hepatitis C and B viruses: clinical and histological study in Saudi patients. *Hepatogastroenterology* 1997;44:1404–6.
225. Kew M, Yu M, Kedda M, Coppin A, Sarkin A, Hodgkinson J. The relative roles of hepatitis B and C viruses in the etiology of hepatocellular carcinoma in southern African blacks. *Gastroenterology* 1997;112:184–7.
226. Chu C, Yeh C, Liaw Y. Low-level viremia and intracellular expression of hepatitis B surface antigen (HBsAg) in HBsAg carriers with concurrent hepatitis C virus infection. *J Clin Microbiol* 1998;36:2084–6.
227. Crespo J, Lozano J, de la Cruz F, et al. Prevalence and significance of hepatitis C viremia in chronic active hepatitis B. *Am J Gastroenterol* 1994;89:1147–51.
228. Dai C, Yu M, Chuang W, et al. Influence of hepatitis C virus on the profiles of patients with chronic hepatitis B virus infection. *J Gastro Hepatol* 2001;16:636–40.
229. Pontisso P, Gerotto M, Ruvoletto M, et al. Hepatitis C genotypes in patients with dual hepatitis B and C virus infection. *J Med Virol* 1996;48:157–60.
230. Pontisso P, Ruvoletto M, Fattovich G, et al. Clinical and virological profiles in patients with multiple hepatitis virus infections. *Gastroenterology* 1993;105:1529–33.
231. Sato S, Fujiyama S, Tanaka M, et al. Coinfection of hepatitis C virus in patients with chronic hepatitis B infection. *J Hepatol* 1994;21:159–66.
232. Ohkawa K, Hayashi N, Yuki N, et al. Long-term follow-up of hepatitis B virus and hepatitis C virus replicative levels in chronic hepatitis patients coinfecting with both viruses. *J Med Virol* 1995;46:258–64.
233. Jardi R, Rodriguez F, Buti M, et al. Role of hepatitis B, C, and D viruses in dual and triple infection: influence of viral genotypes and hepatitis B precore and basal core promoter mutations on viral replicative interference. *Hepatology* 2001;34:404–10.
234. Liaw Y. Concurrent hepatitis B and C virus infection: Is hepatitis C virus stronger? *J Gastro Hepatol* 2001;16:597–8.
235. Liaw Y. Hepatitis C virus superinfection in patients with chronic hepatitis B virus infection. *J Gastroenterol* 2002;37:65–8.
236. Liu C, Chen P, Lai M, Kao J, Jeng Y, Chen D. Ribavirin and interferon is effective for hepatitis C virus clearance in hepatitis B and C dually infected patients. *Hepatology* 2003;37:568–76.
237. Hung C, Lee C, Lu S, et al. Combination therapy with interferon-alpha and ribavirin in patients with dual hepatitis B and hepatitis C virus infection. *J Gastro Hepatol* 2005;20:727–32.
238. Chuang W, Dai C, Chang W, et al. Viral interaction and responses in chronic hepatitis C and B coinfecting patients with interferon-alpha plus ribavirin combination therapy. *Antivir Ther* 2005;10:125–33.
239. Yalcin K, Degertekin H, Yildiz F, Kilinc N. A severe hepatitis flare in an HBV-HCV coinfecting patient during combination therapy with alpha-interferon and ribavirin. *J Gastroenterol* 2003;38:796–800.
240. Marrone A, Zampino R, D’Onofrio M, Ricciotti R, Ruggiero G, Utili R. Combined interferon plus lamivudine treatment in young patients with dual HBV (HBeAg positive) and HCV chronic infection. *J Hepatol* 2004;41:1064–5.
241. Huang E, Wright T, Lake J, Combs C, Ferrell L. Hepatitis B and C coinfections and persistent hepatitis B infections: clinical outcome and liver pathology after transplantation. *Hepatology* 1996;23:396–404.

242. Rifai K, Wedemeyer H, Rosenau J, et al. Longer survival of liver transplant recipients with hepatitis virus coinfections. *Clin Transplant* 2007;21(2):258-64.
243. Weltman M, Brotodihardjo A, Crewe E, et al. Coinfection with hepatitis B and C or B, C and delta viruses results in severe chronic liver disease and responds poorly to interferon-alpha treatment. *J Viral Hepat* 1995;2:39-45.
244. Sterling R. Triple infection with human immunodeficiency virus, hepatitis C virus, and hepatitis B virus: a clinical challenge. *Am J Gastroenterol* 2003;98:2130-4.
245. Hadziyannis S. Decreasing prevalence of hepatitis D virus infection. *J Gastro Hepatol* 1997;12:745-6.
246. Farci P. Delta hepatitis: an update. *J Hepatol* 2003;39(Suppl 1):S212-9.
247. Rizzetto M, Hadziyannis S, Hansson B, et al. Hepatitis delta virus infection in the world: epidemiological patterns and clinical expression. *Gastroenterol Int* 1992;5:18-32.
248. Casey J, Brown T, Colan E, et al. A genotype of hepatitis D virus that occurs in northern South America. *Proc Natl Acad Sci USA* 1993;90:9016-20.
249. CDC. Hepatitis Surveillance Report. *MMWR* 1990;53:23.
250. Rizzetto M, Ponzetto A, Forzani I. Epidemiology of hepatitis delta virus: overview. *Prog Clin Biol Res* 1991;364:1-20.
251. Mumtaz K, Hamid S, Adil S, et al. Epidemiology and clinical pattern of hepatitis delta virus infection in Pakistan. *J Gastro Hepatol* 2005;20:1503-7.
252. Wu J, Chen T, Huang Y, et al. Natural history of hepatitis D viral superinfection: significance of viremia detected by polymerase chain reaction. *Gastroenterology* 1995;108:796-802.
253. Saracco G, Rosina F, Brunetto M, et al. Rapidly progressive HBsAg-positive hepatitis in Italy. The role of hepatitis delta virus infection. *J Hepatol* 1987;5:274-81.
254. Niro G, Ciancio A, Gaeta G, et al. Pegylated interferon alpha-2b as monotherapy or in combination with ribavirin in chronic hepatitis delta. *Hepatology* 2006;44:713-20.
255. Castelnau C, Gal F, Ripault M, et al. Efficacy of peginterferon alpha-2b in chronic hepatitis delta: relevance of quantitative RT-PCR for follow-up. *Hepatology* 2006;44(728-35).
256. Gunsar F, Akarca U, Ersoz G, et al. Two-year interferon therapy with or without ribavirin in chronic delta hepatitis. *Antivir Ther* 2005;10:721-6.
257. Kaymakoglu S, Karaca C, Demir K, et al. Alpha interferon and ribavirin combination therapy of chronic hepatitis D. *Antimicrob Agents Chemother* 2005;49:1135-8.
258. Niro G, Ciancio A, Tillman H, et al. Lamivudine therapy in chronic delta hepatitis: a multicentre randomized controlled pilot study. *Aliment Pharmacol Ther* 2005;22:227-32.
259. Rosina F, Conoscitore P, Smedile A, et al. Treatment of chronic hepatitis D with thymus-derived polypeptide thymic humoral factor-gamma 2: a pilot study. *Dig Liver Dis* 2002;34:285-9.
260. Gaudin J, Faure P, Godinot H, et al. The French experience of treatment of chronic type D hepatitis with a 12-month course of interferon alpha-2B. Results of a randomized controlled trial. *Liver* 1995;15:45-52.
261. Farci P, Mandas A, Coiana A, et al. Treatment of chronic hepatitis D with interferon alfa-2a. *N Engl J Med* 1994;330:88-94.
262. Kleiner D, Di Bisceglie A, Axiotis C, et al. Prolonged alpha interferon therapy for chronic delta hepatitis: effect on liver histopathology. *Prog Clin Biol Res* 1993;382:365-71.
263. Lau D, Kleiner D, Park Y, et al. Resolution of chronic delta hepatitis after 12 years of interferon alfa therapy. *Gastroenterology* 1999;117:1229-33.
264. Farci P, Roskams T, Chessa L, et al. Long-term benefit of interferon alpha therapy of chronic hepatitis D: regression of advanced hepatic fibrosis. *Gastroenterology* 2004;126:1740-9.

265. Ferenci P, Formann E, Romeo R. Successful treatment of chronic hepatitis D with a short course of peginterferon alfa-2a. *Am J Gastroenterol* 2005;100:1626–7.
266. Erhardt A, Gerlich W, Starke C, et al. Treatment of chronic hepatitis delta with pegylated interferon-alpha;2b. *Liver Int* 2006;26(7):805–10.
267. Castelnau C, Le Gal F, Ripault M, et al. Efficacy of peginterferon alpha-2b in chronic hepatitis delta: Relevance of quantitative RT-PCR for follow-up. *Hepatology* 2006;44(3):728–35.
268. Berk L, de Man R, Housset C, et al. Alpha lymphoblastoid interferon and acyclovir for chronic hepatitis delta. *Prog Clin Biol Res* 1991;364:411–20.
269. Vietheer P, Netter H, Sozzi T, et al. Failure of the lamivudine-resistant rtM204I hepatitis B virus mutants to efficiently support hepatitis delta virus secretion. *J Virol* 2005;79:6570–3.
270. Andreone P, Spertini F, Negro F. Lamivudine-associated remission of chronic hepatitis delta. *Ann Intern Med* 2000;132:598.
271. Lau D, Doo E, Park Y, et al. Lamivudine for chronic delta hepatitis. *Hepatology* 1999(30):546–9.
272. Wolters L, van Nunen A, Honkoop P, et al. Lamivudine-high dose interferon combination therapy for chronic hepatitis B patients co-infected with the hepatitis D virus. *J Viral Hepat* 2000;7:428–34.
273. Lok A, Liang R, Chiu E, Wong K, Chan T, Todd D. Reactivation of hepatitis B virus replication in patients receiving cytotoxic therapy. Report of a prospective study. *Gastroenterology* 1991;100(1):182–8.
274. Levy P, Marcellin P, Martinot-Peignoux M, Degott C, Nataf J, Benhamou J. Clinical course of spontaneous reactivation of hepatitis B virus infection in patients with chronic hepatitis B. *Hepatology* 1990;12(3 Pt 1):570–4.
275. Yeo W, Johnson P. Diagnosis, prevention and management of hepatitis B virus reactivation during anticancer therapy. *Hepatology* 2006;43(2):209–20.
276. Yeo W, Ho W, Hui P, et al. Use of lamivudine to prevent hepatitis B virus reactivation during chemotherapy in breast cancer patients. *Breast Cancer Res Treat* 2004;88(3):209–15.
277. Hui C, Cheung W, Zhang H, et al. Kinetics and risk of de novo hepatitis B infection in HBsAg–negative patients undergoing cytotoxic chemotherapy. *Gastroenterology* 2006;131:59–68.
278. Lau G, Lie A, Liang R. Prophylactic lamivudine therapy for hepatitis B patients undergoing immunosuppressive therapy. *Blood* 2002;100(8):3054.
279. Yeo W, Zee B, Zhong S. Comprehensive analysis of risk factors associating with Hepatitis B virus (HBV) reactivation in cancer patients undergoing cytotoxic chemotherapy. *Br J Cancer* 2004;90(7):1306–11.
280. Lau G, He M, Fong D, et al. Preemptive use of lamivudine reduces hepatitis B exacerbation after allogeneic hematopoietic cell transplantation. *Hepatology* 2002;36(3):702–9.
281. Lau G, Yiu H, Fong D, et al. Early is superior to deferred preemptive lamivudine therapy for hepatitis B patients undergoing chemotherapy. *Gastroenterology* 2003;125(6):1742–9.
282. Rossi G, Pelizzari A, Motta M, Puoti M. Primary prophylaxis with lamivudine of hepatitis B virus reactivation in chronic HbsAg carriers with lymphoid malignancies treated with chemotherapy. *Br J Haematol* 2001;115:58–62.
283. Chan T, Fang G, Tang C, Cheng I, Lai K, Ho S. Preemptive lamivudine therapy based on HBV DNA level in HBsAg-positive kidney allograft recipients. *Hepatology* 2002;36:1246–52.
284. Idilman R. Duration of lamivudine prophylaxis in inactive hepatitis B virus carriers with haemato/oncological malignancies who receive chemotherapy. *Gut* 2006;55(8):1208–9.
285. Lim L, Wai C, Lee Y, et al. Prophylactic lamivudine prevents hepatitis B reactivation in chemotherapy patients. *Aliment Pharmacol Ther* 2002;16:1939–44.

286. Kohrt H, Ouyang D, Keeffe E. Systematic review: lamivudine prophylaxis for chemotherapy-induced reactivation of chronic hepatitis B virus infection. *Aliment Pharmacol Ther* 2006;24(7):1003-16.
287. Lau J, Lai C, Lin H, et al. Fatal reactivation of chronic hepatitis B virus infection following withdrawal of chemotherapy in lymphoma patients. *Q J Med* 1989;73(270):911-7.
288. Lalazar G, Rund D, Shouval D. Screening, prevention and treatment of viral hepatitis B reactivation in patients with haematological malignancies. *Br J Haematol* 2007;136(5):699-712.
289. Todo S, Demetris A, Van Thiel D, et al. Orthotopic liver transplantation for patients with hepatitis B virus-related liver disease. *Hepatology* 1991;13:13:619.
290. Gish R, McCashland T. Hepatitis B in liver transplant recipients. *Liver Transpl* 2006;12(11 ):S54-64.
291. No authors listed. Viral hepatitis guidelines in hemodialysis and transplantation. *Am J Transplant* 2004 4 (Suppl 10):72-82.
292. Terrault N, Vyas G. Hepatitis B immune globulin preparations and use in liver transplantation. *Clinics in liver disease* 2003;7(3):537-50.
293. Gane E, Angus P, Strasser S, et al. Lamivudine Plus Low-Dose Hepatitis B Immunoglobulin to Prevent Recurrent Hepatitis B Following Liver Transplantation. *Gastroenterology* 2007;132(3):931-7.
294. Han S, Joshua Ofman J, Holt C, et al. An efficacy and cost-effectiveness analysis of combination hepatitis B immune globulin and lamivudine to prevent recurrent hepatitis B after orthotopic liver transplantation compared with hepatitis B immune globulin monotherapy. *Liver Transpl* 2000;6(6):741-8.
295. Bartholomew M, Jansen R, Jeffers L, et al. Hepatitis-B-virus resistance to lamivudine given for recurrent infection after orthotopic liver transplantation. *Lancet* 1997;349:20-2.
296. Ling R, Mutimer D, Ahmed M. Selection of mutations in the hepatitis B virus polymerase during therapy of transplant recipients with lamivudine. *Hepatology* 1996;24:711-3.
297. Tipples G, Ma M, Fischer K, Bain V, Kneteman N, Tyrrell D. Mutation in HBV RNA-dependent DNA polymerase confers resistance to lamivudine in vivo. *Hepatology* 1996;24:714-7.
298. Liaw Y, Chien R, Yeh C, Tsai S, Chu C. Acute exacerbation and hepatitis B virus clearance after emergence of YMDD motif mutation during lamivudine therapy. *Hepatology* 1999;30:567-72.
299. Chayama K, Suzuki Y, Kobayashi M. Emergence and takeover of YMDD motif mutant hepatitis B virus during long-term lamivudine therapy and re-takeover by wild type after cessation of therapy. *Hepatology* 1998;27:1711-6.
300. Honkoop P, Niesters H, de Man R. Lamivudine resistance in immunocompetent chronic hepatitis B: Incidence and patterns. *J Hepatol* 1997;26:1393-5.
301. Seta T, Yokosuka O, Imazeki F. Emergence of YMDD motif mutants of hepatitis B virus during lamivudine treatment of immunocompetent type B hepatitis patients. *J Med Virol* 2005;60:8-16.
302. Perrillo R, Schiff E, Yoshida E. Adefovir dipivoxil for the treatment of lamivudine-resistant hepatitis B mutants. *Hepatology* 2000;32:129-34.
303. Wai C, Da Costa M, Sutedja D, et al. Long-term results of liver transplant in patients with chronic viral hepatitis-related liver disease in Singapore. *Singapore Med J* 2006;47(7):588-91.
304. Lo C, Fan S, Liu C, et al. Ten-year experience with liver transplantation at Queen Mary Hospital: retrospective study. *Hong Kong Med J* 2002;8:240-4.
305. Shitrit A, Kramer M, Bakal I, Morali G, Ben Ari Z, Shitrit D. Lamivudine prophylaxis for hepatitis B virus infection after lung transplantation. *Ann Thorac Surg* 2006;81(5):1851-2.
306. Murakami R, Amada N, Sato T, et al. Reactivation of hepatitis and lamivudine therapy in 11 HBsAg-positive renal allograft recipients: a single centre experience. *Clin Transplant* 2006;20(3):351-8.

307. Abdelmalek M, Pasha T, Zein N, et al. Subclinical reactivation of hepatitis B virus in liver transplant recipients with past exposure. *Liver Transpl* 2003;9:1253.
308. Duhart B, Honaker M, Shokouh-Amiri M, et al. Retrospective evaluation of the risk of hepatitis B virus reactivation after transplantation. *Transpl Infect Dis* 2003;5:126.
309. Tse K, Ho L, Lao T. The impact of maternal HBsAg carrier status on pregnancy outcomes: a case-control study. *J Hepatol* 2005;43(5):771-5.
310. Hieber J, Dalton D, Shorey J, Combes B. Hepatitis and pregnancy. *J Pediatr* 1977;91(4):545-9.
311. Pavel A, Tirsia E, Maior E, Cristea A. Detrimental effects of hepatitis B virus infection on the development of the product of conception. *Virologie* 1983;34(1):35-40.
312. Su W, Wang P, Yuan C, Chang S. Fetal meconium peritonitis in the infant of a woman with fulminant hepatitis B. *J Reprod Med* 2002;47(11):952-4.
313. Jhaveri R, Verma R, Rosenfeld W, Salazar D, Dosik H, Evans H. Chromosomal abnormality in the newborns of hepatitis B surface antigen (HBsAg) carrier mothers. *Clin Pediatr (Phila)* 1980;19(1):66-8.
314. Lao T, Tse K, Chan L, Tam K, Ho L. HBsAg carrier status and the association between gestational diabetes with increased serum ferritin concentration in Chinese women. *Diabetes Care* 2003;26(11):3011-6.
315. Sookoian S. Effect of pregnancy on pre-existing liver disease: Chronic viral hepatitis. *Ann Hepatol* 2006;5(3):190-7.
316. Stevens C, Beasley R, Tsui J, Lee W. Vertical transmission of hepatitis B antigen in Taiwan. *N Engl J Med* 1975;292:771-4.
317. Akhter S, Talukder M, Bhuiyan N, Chowdhury T, Islam M, Begum S. Hepatitis B virus infection in pregnant mothers and its transmission to infants. *Indian J Pediatr* 1992;59:411-5.
318. Okada K, Kamiyama I, Inomata M, Imai M, Miyakawa Y. E antigen and anti-e in the serum of asymptomatic carrier mothers as indicators of positive and negative transmission of hepatitis B virus to their infants. *N Engl J Med* 1976;294:746-9.
319. Aggarwal R, Ranjan P. Preventing and treating hepatitis B infection. *BMJ* 2004;329:1080-6.
320. Beasley R, Hwang L, Lee G, et al. Prevention of perinatally transmitted hepatitis B virus infections with hepatitis B immune globulin and hepatitis B vaccine. *Lancet* 1983;2:1099-102.
321. Lee S, Lo K, Tsai Y, et al. Role of caesarean section in prevention of mother-infant transmission of hepatitis B virus. *Lancet* 1988;2(8615):833-4.
322. Wang J, Zhu Q, Zhang X. Effect of delivery mode on maternal-infant transmission of hepatitis B virus by immunoprophylaxis. *Chin Med J (Engl)* 2002;115(10):1510-2.
323. Atkinson W, Pickering L, Schwartz B, Weniger B, Iskander J, Watson J. General recommendations on immunization. Recommendations of the Advisory Committee on Immunization Practices (ACIP) and the American Academy of Family Physicians (AAFP). *MMWR Recomm Rep* 2002;51(RR-2):1-35.
324. Wang J, Zhu Q, Wang X. Breastfeeding does not pose any additional risk of immunoprophylaxis failure on infants of HBV carrier mothers. *Int J Clin Pract* 2003;57(2):100-2.
325. Lee C, Gong Y, Brok J, Boxall E, Gluud C. Effect of hepatitis B immunisation in newborn infants of mothers positive for hepatitis B surface antigen: systematic review and meta-analysis. *BMJ* 2006;332(7537):328-36.
326. Wong V, Ip H, Reesink H, et al. Prevention of the HBsAg carrier state in newborn infants of mothers who are chronic carriers of HBsAg and HBeAg by administration of hepatitis-B vaccine and hepatitis-B immunoglobulin. Doubleblind randomised placebo-controlled study. *Lancet* 1984;1:921-6.

327. Euler G, Copeland J, Rangel M, Williams W. Antibody response to postexposure prophylaxis in infants born to hepatitis B surface antigen-positive women. *Pediatr Infect Dis* 2003;22:123-9.
328. Aggarwal R, Ranjan P. Preventing and treating hepatitis B infection. *BMJ* 2004;329:1080-6.
329. Mast E, Margolis H, Fiore A, et al. A comprehensive immunization strategy to eliminate transmission of hepatitis B virus infection in the United States: recommendations of the Advisory Committee on Immunization Practices (ACIP) part 1: immunization of infants, children, and adolescents. *MMWR Recomm Rep* 2005;54:1-31.
330. van Zonneveld M, van Nunen A, Niesters H, de Man R, Schalm S, Janssen H. Lamivudine treatment during pregnancy to prevent perinatal transmission of hepatitis B virus infection. *J Viral Hepatol* 2003;10:294-7.
331. Su G, Pan K, Zhao N, Fang S, Yang D, Zhou Y. Efficacy and safety of lamivudine treatment for chronic hepatitis B in pregnancy. *World J Gastroenterol* 2004;10(6):910-2.
332. Kazim S, Wakil S, Khan L, Hasnain S, Sarin S. Vertical transmission of hepatitis B virus despite maternal lamivudine therapy. *Lancet* 2002;359(9316):1488-9.
333. Hill J, Sheffield J, Kim M, Alexander J, Sercely B, Wendel G. Risk of hepatitis B transmission in breast-fed infants of chronic hepatitis B carriers. *Obstet Gynecol* 2002;99(6):1049-52.
334. Wong V, Lee A, Henrietta M. Transmission of hepatitis B antigens from symptom free carrier mothers to the fetus and the infant. *Br J Obstet Gynaecol* 1980;87:958-65.
335. Larke R, Haworth J, Read J. Breast-feeding by mothers positive for HBsAg. *Can Med Assoc J* 1977;116(12):1344.
336. Tseng R, Lam C, Tam J. Breastfeeding babies of HBsAg positive mothers [letter]. *Lancet* 1988;2:1032.
337. Beasley R, Stevens C, Shiao I, Meng H. Evidence against breastfeeding as a mechanism for vertical transmission of hepatitis B. *Lancet* 1975;2:740-1.
338. De Martino M, Appendino C, Resti M, Rossi M, Muccioli A, Vierucci A. Should hepatitis B surface antigen positive mothers breastfeed? *Arch Dis Child* 1985;60:972-4.
339. Lee A, Henrietta M, Wong V. Mechanisms of maternal-fetal transmission of hepatitis B virus. *J Infect Dis* 1978;138:668-71.
340. Beasley R, Trepo C, Stevens C, Szmuness W. The E Antigen and Vertical Transmission of Hepatitis B Surface Antigen. *Am J Epidemiol* 1977;105(2):94-8.





**Digestive Health Foundation**

Gastroenterological Society of Australia

PO Box 508, Mulgrave

Victoria 3170, Australia

Phone: 1300 766 176

E-mail: [gesa@gesa.org.au](mailto:gesa@gesa.org.au)

Website: [www.gesa.org.au](http://www.gesa.org.au)